

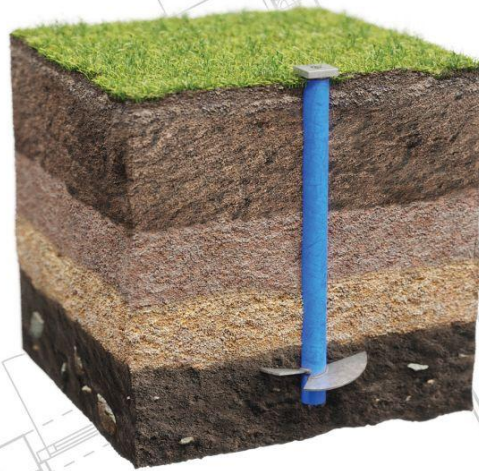











Katana Screw Pile PERFORMANCE GUIDE

**Technical design, specification, installation and compliance
information for architects, engineers, builders, building
surveyors and end users.**



The Performance Guide

Contents

	1.0 Introduction to Katana Foundations	3
	Katana Screw Pile Overview	5
	2.0 Katana Helical Plate Screw Pile Technical Specification and Performance	10
	3.0 How to Design with the Katana Screw Pile	29
	Installation & Certification	50
	Appendix A: Screw Capacity for Uplift Loads	65
	Appendix B: Capacity of Edge Beam Connector	66
	Appendix C: Lateral Load Capacity Tables	68
	Revision Control	72
	Installer Certification Questions and Answers	73

1.0 Katana Foundations

IN THIS SECTION:

- Introduction
- Katana Helical Plate Screw Pile Overview
- Katana Helical Plate Design Features
- Product Range
- Pile Options
- Accessories and Connectors

Introduction

At Katana Foundations, we strive to lead with best practice in everything we do. The Katana Helical Plate Screw Pile Performance Guide demonstrates our commitment to transparency and collaboration with the various businesses that work with our products.

This document is primarily for use by our installers and suppliers but also as a guide for our customers and the engineers and building professionals that our clients engage with.

It is intended that this document will provide information for compliant design, testing, installation and certification of screw piles. We trust this document will assist in your understanding and the proper application of screw piles within the residential and light commercial building sector.

Should you have any questions or require further information, please feel free to contact us directly or access our additional resources below:



Email us at
info@katanafoundations.com.au



Our blog is packed with helpful design and engineering tips, application info and more
katanafoundations.com.au/news



Our website has all technical product information and brochures
katanafoundations.com.au



Our YouTube channel helps you learn faster with our ["how-to" videos](#)



Our LinkedIn Page is up to date with the latest [company news](#) at Katana



Our Facebook page is the best way to follow [our content](#) as it gets published

Katana Helical Plate Screw Pile Overview

The patented Katana Helical Plate Screw Pile, is a twin-helical plate design foundation steel screw pile. It is made with high-tensile steel to deliver high-performance foundations.

Screw piles transfer the structural loads to a firm stratum, providing a significantly stronger foundation.

The Top Plate / Drive nut

The top of the pile is capped with a 16mm thick plate with a 36mm threaded hole to accept various Katana pile accessories.

The top plate, when used with the Katana drive tool, has the safety benefit of engaging the pile to reduce the likelihood of the pile falling out of the drive head during the drilling process.

The Pipe

The pipe section (shaft) is made from Grade 400 MPa (min) high-tensile steel. It comes in a range of thicknesses, diameters and lengths to suit various applications and drilling depths.

The Twin Helical Plates

The helix has been symmetrically designed to be one of the most efficient cutting devices for a screw pile. The result is a screw pile that can be drilled faster and deeper into harder soils. The helix diameter ranges from 250 mm to 350 mm, depending on the pile size.

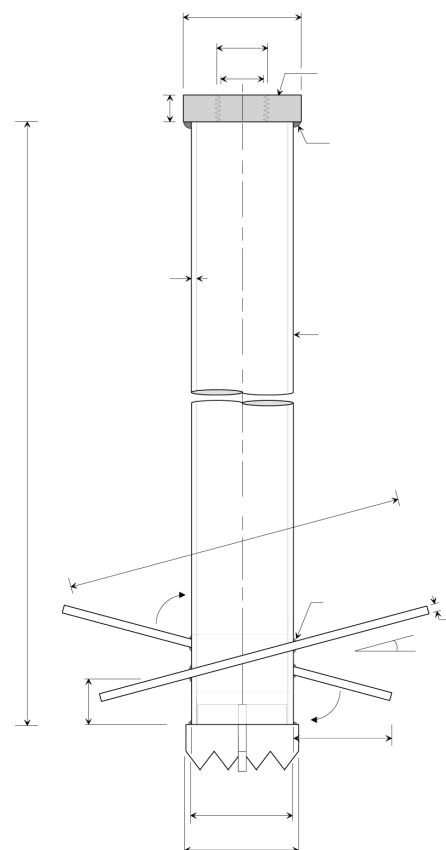

The Cutting Comb

As the first point of contact with the soil, the cutting comb serves two purposes. Firstly it makes drilling easier by the design of the teeth and being able to cut through hard material. Secondly it makes vertical alignment more accurate by the symmetry of the cutting teeth and twin fin helical blades.



Katana Helical Plate Design Features

Most types of foundations try to wrestle mother nature into submission – and lose. We designed the Katana Screw Pile to work with the earth, so it would deliver superior connection between the structure and firm stratum below ground level. The Katana Screw Pile provides foundations that are more predictable, stable, quantifiable, cost effective and low risk.

 <p>Australian Owned & Manufactured</p>	 <p>Fabricated from Australian made pipe and plate</p>	 <p>CodeMarked across Australia and New Zealand</p>
 <p>Special mill 400+ MPa high-tensile yield feed</p>	 <p>A full range of piles: 80kN, 100kN and 150kN</p>	 <p>Stock fittings for raised floor and prefabricated modular projects</p>
 <p>No spoil during drilling and no cartage/disposal costs</p>	 <p>No unsafe open augered holes requiring covers or fencing</p>	 <p>Cheaper than concrete bored piers and easier to install</p>
 <p>No concrete pumping, labour and overruns</p>	 <p>Accurate verification of capacity by torque</p>	 <p>Low noise and minimal vibration</p>
 <p>Longer life - options to cap, galvanise or electroplate</p>	 <p>Complete installation certification</p>	<p>For more on the features and benefits of the Katana Screw Pile, see the "Katana Foundations Brochure"</p> <p>https://katanafoundations.com.au/foundation-systems/technical-re-sources/</p>

Product Range

The Katana Screw Pile range was specifically designed and tested for the Australian and New Zealand residential market. The core range consists of 3 screw piles sizes with load capacity ranging from 80kN to 150kN to suit a range of application needs. Each screw pile is available in customisable lengths up to 4 metres and can be connected to extension piles for applications requiring deeper foundations.

Shaft (diameter x thickness)	Helix (diameter x thickness)	Lengths (and increments)	Typical Capacity (in stiff soils)
76.1mm x 4.0mm	250mm x 8mm	1.0m - 4.0m 0.5m increments	80 kN
76.1mm x 4.0mm	300 x 8mm	1.0m - 4.0m 0.5m increments	100 kN
88.9mm x 5.5mm	350 x 10mm	1.0m - 4.0m 0.5m increments	150 kN
88.9mm x 5.5mm	2No 350 x 10mm	1.0m - 4.0m 0.5m increments	200 kN

Pile Options

The Katana Screw Pile can be further customised for your application requirements.

Pipe Sealing	Unsealed Sealed with welded steel plate at the bottom
Pile Coatings	Uncoated Hot dip galvanised Zinc electroplated
Applied Coatings (applied by the customer)	Two-pack or fusion bonded epoxy or wrapping tapes

Accessories and Connectors

Katana Foundations have developed a range of connectors and accessories to complement the core Screw Pile product. These components enable the Katana pile to be used across a broad range of foundation and building applications as well as complimenting various types of raised floors.

All components have been designed and tested to provide a connected “system” capable of delivering the required load capacity and other engineering design requirements - thus eliminating the need for ad hoc connectors and providing greater design certainty.

Extend a pile?

The extension is used where pile lengths of more than 3.5 metres are required, or a nominated pile length **needs to be extended**.

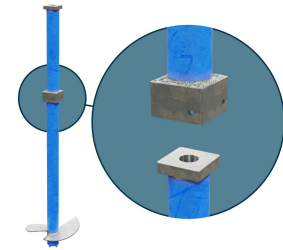

Connect the pile to the footing?

This adjustable connector can be used for **screw pile embedment** into concrete footings or concrete slabs.

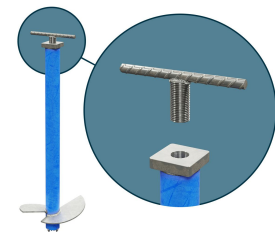

Support the slab?

Engineers' specify slab being supported directly on the pile or with the use of a slab plate.

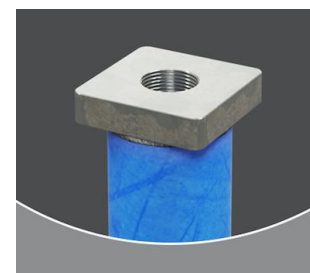

Cut a Pile?

These adaptors are used where **piles are cut on-site.**

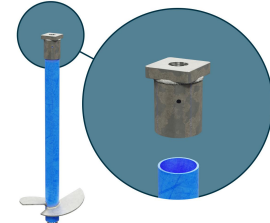
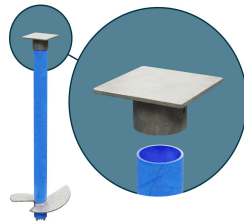

Raised Floor?

Various options for bracing and connecting bearers to the pile

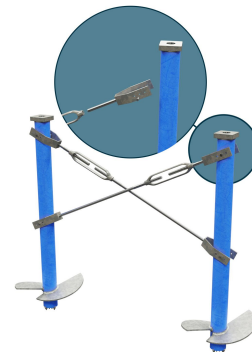

Do you need a different connector?

If you have an application that is not supported by the above connectors and accessories, get in touch with us, as we may be able to fabricate a bespoke connector for your particular foundation. We're always interested in helping people use the Katana Screw Pile in new ways and for new building applications.

2.0 Katana Helical Plate Screw Pile Technical Specification and Performance

IN THIS SECTION:

- CodeMark
- Materials and Manufacturing
- Key Technical Specifications
- Engineering Details
- Compression Load Capacity
- Concrete Bearing Stress
- Torque Capacity
- Tension Load Capacity
- Lateral Load Capacity
- Performance Summary of uncut and cut piles
- Corrosion
- Fill Material

CodeMark

Katana Foundations are the only Australian or New Zealand screw pile company to have achieved CodeMark certification for their screw pile - the product, fabrication and installation.

Read more about the importance and advantages of CodeMark:

<https://www.abcb.gov.au/Product-Certification/CodeMark-Certification-Scheme>

Download a copy of the Katana Aus or NZ CodeMark:

<https://katanafoundations.com.au/foundation-systems/technical-resources/>

Materials and Manufacturing

Katana Foundations source special high strength feed for the Katana Screw Pile from the Bluescope Steel Mill

<http://www.bluescopesteel.com.au/>. This is then sent to one of



two rolling mills in Brisbane to be rolled into CHS pipe. The minimum yield strength of the pipe is 400 MPa.

The pipe is shipped to Stoddart <https://www.stoddart.com.au/>, our manufacturing partner, where the piles and accessories are fabricated for dispatch around Australia and New Zealand.

Dimensions and Tolerances

The steel hollow sections conform to the manufacturing tolerances specified in AS 1163 - 2016.

Welding

Weld specifications can be found in our **Katana Pile Product Statement** where e3K Global (Gilmore Engineers) have detailed the welding specifications. <https://katanafoundations.com.au/foundation-systems/technical-resources/>



Certification of Materials

Test certificates are issued with the Katana piles for the steel used in the manufacture of the product in accordance with AS/NZS 3679.1 and tests performed by the manufacturer to establish compliance with the Standard and for CodeMark compliance.

Manufacturing Traceability



Full traceability of every manufactured component of the Katana Screw Pile can be provided. Each fabricated pile and accessory is inspected and approved by the manufacturer.

Key Technical Specifications

The steel Katana Pile shaft, bearing plates and helix are manufactured according to the following minimum technical specification in accordance with AS/NZS 1554.1. All steel complies with AS 4100.

	Standard	NATA	Manufacture	Value	Unit
MINIMUM YIELD STRENGTH					
Pipe	AS/NZS 1163	632 and 17051	AS 1554.1	400	MPa
Helix	AS/NZS 3678	632 and 631	AS 1554.1	350	MPa
Plate	AS/NZS 3678	632 and 631	AS 1554.1	350	MPa

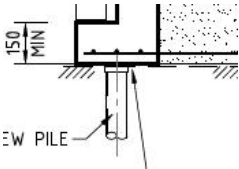
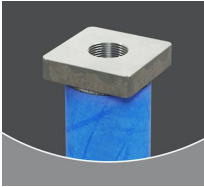
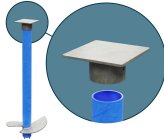
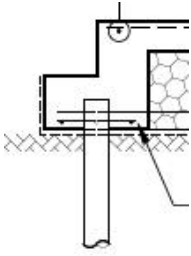
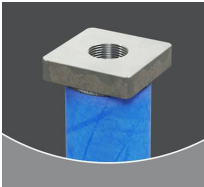
Engineering Details:

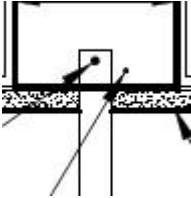
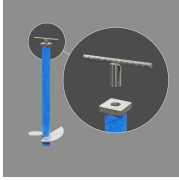
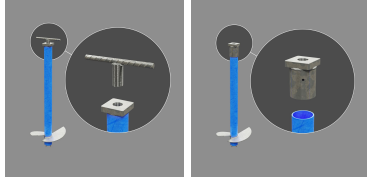
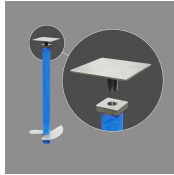
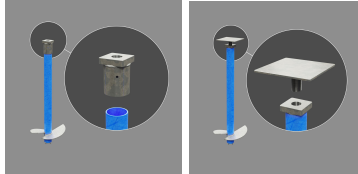
Unengaged / Engaged	Typical Engineers detail	Uncut Pile	Cut Pile
<p>Unengaged pile - Top 85x85x16 plate approved by the engineer</p>			
<p>Engaged pile - Engineer details engaged pile (Uplift = 0kN)</p>			
<p>Engaged pile - Engineer details engaged pile with edge tie (Uplift < 27.5kN)</p>			
<p>Engaged pile - Engineer details engaged pile with edge tie (Uplift < 50kN)</p>	<p>As above - check engineering notes for uplift forces</p>	 <p>Slab Plate (100x100x6)</p>	 <p>Cut Cap and Slab Plate Cut cap *welded to pile or hole through pile and cut off nut with rebar</p>

Compression Load Capacity

Compression testing is conducted to determine the capacity of the Katana piling products.

Where soft or loose material is identified in the geotechnical report - it is always best practice to undertake a compression test to confirm soil and buckling capacity of the pile.

Load Table: All Safe Working Loads (SWL) stiff clay and dense sand

Product	Compression Load
76.1mm x 4.0mm, 250x8	up to 80kN
76.1mm x 4.0mm, 300x8	up to 100kN
88.9mm x5.5mm, 350x10	up to 150kN
88.9mm x5.5mm, 2No 350x10	up to 200kN

Supporting slabs with the Katana Pile Drive Nut

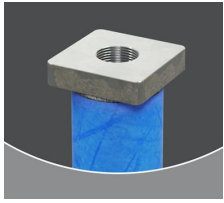
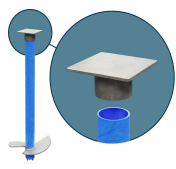
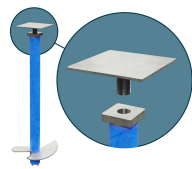
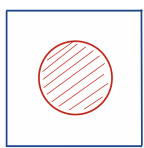
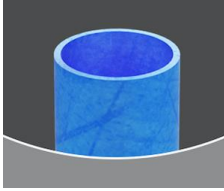
Slab Support	Support Area	Shear Capacity	Bearing Load	Comments
 <p>Drive Nut</p>	$A=85 \times 85$ $A=6,200 \text{ mm}^2$	100kN SWL (centre of footing) 80kN SWL 75mm from the centre	13MPa (80kN SWL)	Empirical testing undertaken by the university of Melbourne on min size footing *Less items subject to corrosion
 <p>Cut Off Plate</p>	$A=3.14 \times r^2$ $A=3.14 \times (52)^2$ $A=8,490 \text{ mm}^2$ *Cut pile	> 100kN SWL (centre of footing) > 80kN SWL 75mm from the centre	10MPa (80kN SWL)	Assume support of an additional 12mm around the 80mm CHS
 <p>Slab Plate</p>	$A=3.14 \times r^2$ $A=3.14 \times (30)^2$ $A=2,826 \text{ mm}^2$ 	No Empirical testing	28 MPa (80kN SWL)	Assume support of an additional 12mm around the 36mm threaded rod *More items subject to corrosion
 <p>Cut Pile</p>	$A=3.14 \times (r_o^2 - r_i^2)$ $A=3.14 \times ((38)^2 - (34)^2)$ $A=904 \text{ mm}^2$	No Empirical testing	88MPa (80kN SWL)	

*Note: Engineers would typically require the concrete to provide additional concrete (for shear and pile tolerance) at the **internal pile locations** with a **cutout (waffle pods) of 300mm x 300mm**.

The structural engineer would be required to verify, through calculations, that the information provided above, correlates with the loads and capacity of the sections that are required for each project.

Torque Capacity

Torque Vs Compression Load

Our pile performance analysis (which is based on compression testing) indicates that when a torque of 4000 Nm is reached on our 76x250 pile, a safe working load of 80kN is achieved in stiff soils.

The torque of 4000 Nm is related back to hydraulic drive pressure which is shown on the pressure vs torque chart of an ED10,000 at 96 bar (converted to 1400 psi).

It is important to note the torsional capacity of the Katana Pile. Katana Piles are made from high strength steel with increased torsional capacity.

$$\text{Torsion capacity} = \phi 0.6 f_y \frac{2(\pi(d_o^4 - d_i^4))}{32} / d_o$$

AS4100. ϕ = design capacity factor, f_y = design yield stress, d_o = outside diameter, d_i = inside diameter.

For a 101 mm ϕ pipe at 4mm thick: assume 250MPa - 350 MPa yield strength steel from a mill ($\phi = 0.9$)*

- *Torsion capacity in theory is 7600 Nm - 10700 Nm*

For a 76.1mm 400MPa - 500MPa high strength steel from a mill with QA ($\phi = 0.989$)

- Torsion capacity in theory is 7300 Nm - 9200 Nm

The **higher yield strength makes a big difference to being able to get your pile in the ground without the need to pre-drill.**

Because our "special" steel is not one of the "official" grades in AS1163 - the mill does not state that on the test certificate as it is a C400L0 product, however test certificates contain the results of regular testing carried out of the steel.



In 2019, Katana Foundations undertook a torsional study involving two masters groups from the University of Melbourne. The **Torsion Paper** is available on our website.

<https://katanafoundations.com.au/foundation-systems/technical-resources>

Tension Load Capacity

Tension testing is used to verify the capacity of the piles installed on a particular site and is carried out where uncertainty - of the soil conditions - may exist for a particular area or site. **It is critical to note** that

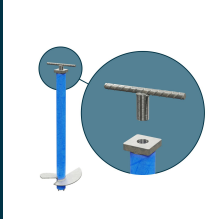
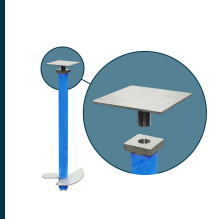
when sand, in particular, is saturated, the uplift capacity is significantly reduced – if in doubt conduct an uplift test.

UPLIFT CAPACITY: Cut pile with pile adaptor		UPLIFT CAPACITY: Uncut pile		
				
Load – tension where piles are cut (3 Buildex Hex head screws rated at 5kN each)	Load – tension where piles are cut (3 M8 Tri-Fixx heavy duty screws rated at 9kN each)	Load – tension Edge Beam Connector (assume 40mm CFW) between the N16 and 36mm threaded bar)	Load – tension 6mm slab plate fully embedded in the concrete footing Plate 150x150x6	Load rated lifting eye bolt with a 36mm thread together with reinforcing – see table below
up to 15kN	up to 27kN	up to 27.5kN*	up to 50kN	Varies**

Where a pile is **cut** and a Pile Cap Adaptor is required for raised floors or Polyvoid slabs, the capacity is limited by the self tapping screws (see tension table above) instead of the capacity of the pile – 80kN for example. Further information can be found in **Appendix A: Screw Capacity for Uplift Loads**

*Concrete Pull out capacity of Edge Beam Connector:

As the reinforcing has combined actions of tension and shear, the Edge Beam Connector was tested, see and achieved a SWL of **27.5kN**. Further information can be found in **Appendix B: Capacity of Edge Beam Connector**.

Options to further increase Uplift Loads

A hole can be drilled through the top of a Katana cut pile and reinforced with a length (detailed in the table below) inserted into the hole to develop the tensile loads required. This is not our preferred method as it reduces the section capacity of the pile and may introduce bearing capacity issues in the concrete.

An eye bolt* with a 36mm thread can be used (only used where the Katana pile is **NOT** cut).

See table can be used as a guide.

Both options need to be signed off by the engineer (ensure reinforcing is a neat fit in the hole or eye bolt):

**Concrete Pull out capacity of Edge Beam Connector:

Approx Tensile Load	Reinforcing - placed centrally in the eye bolt or through a hole drilled in the cut Katana Pile	Eye bolt* Safe Working Load
28kN (2.8t)	12mm 1000mm long	3.0t
50kN (5.0t)	16mm 1500mm long	5.0t
75kN (7.0t)	20mm 2000mm long	7.5t
95kN (9.0t)	24mm 2500mm long	10.0t
110kN (11.0t)	28mm 2800mm long	15.0t

Lateral Load Capacity

Lateral testing is particularly important for raised floor applications and prefabricated buildings to understand the potential deflection of the piles and what bracing may be required. Lateral load capacity tables can be found in Appendix C: Lateral Load Capacity tables

Performance Summary of an UNCUT Katana Pile:

Pile Type	76.1x4 250x8	76.1x4 300x8	88.9x5.5 350x10	88.9x5.5 Twin 350x10
Helix	Single	Single	Single	Twin
Load range	7kN - 200kN	10kN - 200kN	14kN - 230kN	41kN - 300kN
Typical load	80kN	100kN	150kN	200kN
Drive Nut Size	85x85x16	85x85x16	110x110x16	110x110x16
Bearing stress on Drive Nut (MPa)	13	16	13.5	18
	Concrete Bearing stress: 27MPa Uplift Load: 50kN	N/A	N/A	N/A
	Uplift Load: 27.5kN	Uplift Load: 27.5kN	Uplift Load: 27.5kN	Uplift Load: 27.5kN
Raised Floors	76.1x4 250x8	76.1x4 300x8	88.9x5.5 350x10	88.9x5.5 Twin 350x10
	Lock nut to be securely fixed on all raised floor applications	Lock nut to be securely fixed on all raised floor applications	N/A	N/A

Performance Summary of a CUT Katana Pile:

Where the pile can no longer be driven into the soil/rock or has reached the required depth, it will be cut and a cap provided to the top of the pile.

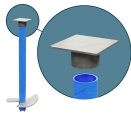
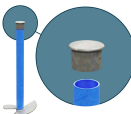
Pile Type	76.1x4 250x8	76.1x4 300x8	88.9x5.5 350x10	88.9x5.5 Twin 350x10
Helix	Single	Single	Single	Twin
Load range	7kN - 200kN	10kN - 200kN	14kN - 230kN	41kN - 300kN
Typical load	80kN	100kN	150kN	200kN
Drive Nut	85x85x16	85x85x16	110x110x16	110x110x16
Bearing stress on Drive Nut (MPa)	13	16	13.5	18
	Uplift Load: 15kN - Hex head 27kN - Tri fixx	Uplift Load: 15kN - Hex head 27kN - Tri fixx	Uplift Load: 15kN - Hex head 27kN - Tri fixx	Uplift Load: 15kN - Hex head 27kN - Tri fixx
	Concrete Bearing Stress: 19MPa	Concrete Bearing Stress: 24MPa	N/A	N/A
	Concrete Bearing Stress: 19MPa	Concrete Bearing Stress: 24MPa	N/A	N/A

Corrosion

Steel Katana piles have been designed in accordance with AS 2159 Section 6.3 with an allowance for sectional loss based on the site corrosion classification and design life. Refer **Katana Corrosion Report** by e3k Global. <https://katanafoundations.com.au/foundation-systems/technical-resources/>

Where the client provides a geotechnical report indicating the exposure classification of the site, the expected lifetime of the pile is able to be calculated according to AS2159.

Typical results from a Geotechnical site investigation report are as per the table below.

Chlorides, pH and Resistivity are used in **AS 2159 (Table 6.5.2)** to determine the in-ground **Exposure Classification of steel piles:**

TABLE 6.5.2(A)
EXPOSURE CLASSIFICATION FOR STEEL PILES—
PILES IN WATER

Exposure conditions	Exposure classification
Sea water—submerged	Severe
Sea water—tidal/splash zone— Cold water (south of 30°S)	Severe
Sea water—tidal splash zone— Tropical/Subtropical water (North of 30°S)	Very severe
Fresh water—soft running water	Moderate

TABLE 6.5.2(B)
EXPOSURE CLASSIFICATION FOR STEEL PILES—
PILES IN REFUSE FILL

Exposure conditions	Exposure classification
Domestic waste	See Note 2
Industrial waste	See Note 2

TABLE 6.5.2(C)
EXPOSURE CLASSIFICATION FOR STEEL PILES—PILES IN SOIL

Exposure conditions			Exposure classification		
pH	Chlorides Cl		Resistivity ohm.cm	Soil condition A*	Soil condition B†
	In soil ppm	In groundwater ppm			
>5	<5000	<1 000	>5 000	Non-aggressive	Non-aggressive
4–5	5000–20,000	1 000–10 000	2 000–5 000	Mild	Non-aggressive
3–4	20,000–50,000	10 000–20 000	1 000–2 000	Moderate	Mild
<3	>50,000	>20 000	<1 000	Severe	Moderate

* Soil conditions A—high permeability soils (e.g., sands and gravels) that are in groundwater
† Soil conditions B—low permeability soils (e.g., silts and clays) or all soils above groundwater

NOTES TO TABLES 6.5.2 (A), 6.5.2 (B) AND 6.5.2 (C):

- 1 Where high levels of sulfates exist (>1000 ppm), sulfate-reducing bacteria may be present and active, sometimes leading to microbiologically induced corrosion. In such cases, classify as ‘mild’ for low permeability soils and ‘moderate’ for high permeability soils.
- 2 Contamination by the tipping of mineral and domestic waste or by spillage from mining, processing or manufacturing industries presents special durability risks due to the presence of certain aggressive acids (both organic and inorganic), salts and solvents, which can chemically attack steel. In the absence of site-specific chemical information, the exposure condition should be assessed as ‘severe’ for domestic refuse tips and ‘very severe’ for industrial/mining waste tips. Chemical and microbiological analysis of the latter may, however, lead to lower risk classification.
- 3 For piles in disturbed soil, consider the assumption of soil A conditions where accelerated corrosion is possible.

Sulfates and pH are used in **AS 2870** to determine the in-ground **Exposure Classification of concrete**:

TABLE 5.2
EXPOSURE CLASSIFICATION FOR CONCRETE IN SULFATE SOILS

Exposure conditions			Exposure classification	
Sulfates (expressed as SO ₄)*		pH	Soil conditions A†	Soil conditions B‡
In soil ppm	In groundwater ppm			
<5000	<1000	>5.5	A2	A1
5000–10 000	1000–3000	4.5–5.5	B1	A2
10 000–20 000	3000–10 000	4–4.5	B2	B1
>20 000	>10 000	<4	C2	B2

* Approximately 100 ppm SO₄ = 80 ppm SO₃

† Soil conditions A—high permeability soils (e.g., sands and gravels) that are in groundwater

‡ Soil conditions B—low permeability soils (e.g., silts and clays) or all soils above groundwater

AS 2159 provides guidance on the treatment of contaminated sites - see note 6 under table 6.4.2 (Severe and Very Severe). For these conditions, we can provide thicker steel, galvanising and even cathodic protection.

Note: Piles in seawater are considered Severe and Very Severe which means salinity should be considered in determining the life of the piles.

The client's geotechnical and/or chemical engineer are required to determine the exposure classification of the soil as in the example below and recommend the protection required. Predicting the corrosion rates, especially on contaminated sites should be undertaken by appropriately qualified Geotechnical Engineers.

TABLE 6.5.3
CORROSION ALLOWANCES FOR STEEL PILES

Exposure classification	Uniform corrosion allowance (mm/year)
Non-aggressive	<0.01
Mild	0.01–0.02
Moderate	0.02–0.04
Severe	0.04–0.1
Very severe ³	>0.1

Expected IN GROUND Life

The life expectancy of a pile is directly related to the Exposure Classification in AS2159 and the thickness of the steel section. Best practice is for a suitably qualified Geotechnical Engineer to determine the Exposure Classification of the soil in order to provide an estimated life of the piles.

Assumptions:

- Ground water well below ground level
- No moisture at ground level
- At end of life - the pile has half its section thickness
- Refer Table 6.4 AS2159

Exposure Classification	Uniform corrosion allowance (mm/year)	Unsealed (corrosion on two surfaces)		Sealed (corrosion only on one surface)	
		76 x 4	88 x 5.5	76 x 4 w/ sealed end#	88 x 5.5 w/ sealed end#
Non Aggressive	< 0.01	100	137	200	275
Mild	0.01 - 0.02	50-100	68-137	100-200	138-275
Moderate **	0.02 - 0.04	25-50	34-68	50-100	68-138
Severe ***	0.04 - 0.1	10-25	13-34	20-50	27-68
Very Severe ****	> 0.1	<10	<13	<20	<27

** Recommend pile is sealed (corrosion only from one side)

*** Recommend that piles have at least 10mm thick walls. Sealed piles cannot be galvanised or zinc coated - paint may come off during the installation process.

**** Steel piles in ground - not recommended

Only applies where pile extensions are NOT used - where extensions are used, assume the pile is unsealed.

A guide for the use of 76x4 piles by incorporating Exposure Classification for steel (pH) and concrete (Sulphates)

		Table 5.2 AS 2870 Exposure classification for concrete		
		A1	A2	B1
Table 6.5.2 (C) AS 2158 Exposure Classification for steel piles - piles in soil	Non Aggressive pH > 5	76x4	76x4 sealed	Galvanised
	Mild pH 4-5	76x4	76x4 sealed	Galvanised
	Moderate pH 3-4	76x4 sealed	76x4 sealed	Galvanised

It is not recommended that pre-drilling is undertaken where soils contain level of sulphates (>1000 ppm)

Expected ABOVE GROUND Life

Where piles are located above ground, Katana Foundations recommends the use of an appropriate corrosion protection system - giving consideration to the expected life of the structure and exposure conditions - to be determined by the design engineer.



	<p>An example of a corrosion protection system that may be specified is the Denso SteelGard 400 (Butyl-based adhesive):</p>
	<p><u>Denso-Butyl Tapes</u></p>

Expected above ground life for Galvanised or Zinc Electroplated Katana Piles

Corrosivity Factor*	Life of uncoated mild steel (2mm) or 2000 um** (years)	Zinc corrosion rate Table 2 ISO 9223 (um/year)	Total Expected life of galvanising) - assume min 55 um* (galv years) Total	Total Expected life of Zinc electroplating assume min 12 um (zinc years) Total
C1	1538	0.1	(550) 2088	(120) 1658
C2	80	0.7	(78.5) 158	(17.1) 97
C3	40	2.1	(26.1) 66	(5.7) 45
C4	25	4.2	(13.1) 38	(2.8) 27
C5	10	8.4	(6.5) 16	(1.4) 11
Cx	2.8	25	(2.2) 5	(0.5) 3

* Coating thicknesses from Fero and C.P. Plating (Stoddart suppliers)

** <https://gaa.com.au/performance-in-various-environments/>

Refer ISO 9223 - add uncoated life of mild steel

For explanations of Corrosivity Factors, see tables below.

Corrosivity category	Comparative corrosion rates for steel and zinc from ISO 9223		
	r_{corr} Unit	Carbon steel	Zinc
C1	$g/(m^2 \cdot a)$	$r_{corr} \leq 10$	$r_{corr} \leq 0.7$
	$\mu m/a$	$r_{corr} \leq 1.3$	$r_{corr} \leq 0.1$
C2	$g/(m^2 \cdot a)$	$10 < r_{corr} \leq 200$	$0.7 < r_{corr} \leq 5$
	$\mu m/a$	$1.3 < r_{corr} \leq 25$	$0.1 < r_{corr} \leq 0.7$
C3	$g/(m^2 \cdot a)$	$200 < r_{corr} \leq 400$	$5 < r_{corr} \leq 15$
	$\mu m/a$	$25 < r_{corr} \leq 50$	$0.7 < r_{corr} \leq 2.1$
C4	$g/(m^2 \cdot a)$	$400 < r_{corr} \leq 650$	$15 < r_{corr} \leq 30$
	$\mu m/a$	$50 < r_{corr} \leq 80$	$2.1 < r_{corr} \leq 4.2$
C5	$g/(m^2 \cdot a)$	$650 < r_{corr} \leq 1,500$	$30 < r_{corr} \leq 60$
	$\mu m/a$	$80 < r_{corr} \leq 200$	$4.2 < r_{corr} \leq 8.4$
CX	$g/(m^2 \cdot a)$	$1,500 < r_{corr} \leq 5,500$	$60 < r_{corr} \leq 180$
	$\mu m/a$	$200 < r_{corr} \leq 700$	$8.4 < r_{corr} \leq 25$

The classification criterion is based on the methods of determination of corrosion rates of standard specimens for the evaluation of corrosivity (see ISO 9226^{xi}).

The corrosion rates, expressed in grams per square metre per year [$g/(m^2 \cdot a)$], are recalculated in micrometres per year ($\mu m/a$) and rounded.

Corrosion rates in category CX are considered extreme. Corrosivity category CX refers to specific marine and marine/industrial environments.

Specific calculation models, guiding corrosion values and additional information on long-term corrosion behaviour, are given in ISO 9224^{xiii}.

Corrosivity category	Corrosivity	Typical environments – Examples from ISO 9223	
		Indoor	Outdoor
C1	Very low	Heated spaces with low relative humidity and insignificant pollution, e.g. offices, schools, museums	Dry or cold zone, atmospheric environment with very low pollution and time of wetness, e.g. certain deserts, Central Arctic/Antarctica
C2	Low	Unheated spaces with varying temperature and relative humidity. Low frequency of condensation and low pollution, e.g. storage, sport halls	Temperate zone, atmospheric environment with low pollution ($\text{SO}_2 < 5 \mu\text{g}/\text{m}^3$), e.g. rural areas, small towns Dry or cold zone, atmospheric environment with short time of wetness, e.g. deserts, subarctic areas
C3	Medium	Spaces with moderate frequency of condensation and moderate pollution from production process, e.g. food-processing plants, laundries, breweries, dairies	Temperate zone, atmospheric environment with medium pollution ($\text{SO}_2: 5 \mu\text{g}/\text{m}^3$ to $30 \mu\text{g}/\text{m}^3$) or some effect of chlorides, e.g. urban areas, coastal areas with low deposition of chlorides Subtropical and tropical zone, atmosphere with low pollution
C4	High	Spaces with high frequency of condensation and high pollution from production process, e.g. industrial processing plants, swimming pools	Temperate zone, atmospheric environment with high pollution ($\text{SO}_2: 30 \mu\text{g}/\text{m}^3$ to $90 \mu\text{g}/\text{m}^3$) or substantial effect of chlorides, e.g. polluted urban areas, industrial areas, coastal areas without spray of salt water or, exposure to strong effect of de-icing salts Subtropical and tropical zone, atmosphere with medium pollution
C5	Very high	Spaces with very high frequency of condensation and/or with high pollution from production process, e.g. mines, caverns for industrial purposes, unventilated sheds in subtropical and tropical zones	Temperate and subtropical zone, atmospheric environment with very high pollution ($\text{SO}_2: 90 \mu\text{g}/\text{m}^3$ to $250 \mu\text{g}/\text{m}^3$) and/or significant effect of chlorides, e.g. industrial areas, coastal areas, sheltered positions on coastline
CX	Extreme	Spaces with almost permanent condensation or extensive periods of exposure to extreme humidity effects and/or with high pollution from production process, e.g. unventilated sheds in humid tropical zones with penetration of outdoor pollution including airborne chlorides and corrosion-stimulating particulate matter	Subtropical and tropical zone (very high time of wetness), atmospheric environment with very high SO_2 pollution (higher than $250 \mu\text{g}/\text{m}^3$) including accompanying and production factors and/or strong effect of chlorides, e.g. extreme industrial areas, coastal and offshore areas, occasional contact with salt spray

Deposition of chlorides in coastal areas is strongly dependent on the variables influencing the transport inland of sea salt, such as wind direction, wind velocity, local topography, wind sheltering islands outside the coast, distance of the site from the sea, etc. Extreme effect by chlorides, which is typical of marine splash or heavy salt spray, is outside of the scope of this Chart. Corrosivity classification of specific service atmospheres, e.g. in chemical industries, is outside of the scope of this Chart. Surfaces that are not sheltered or rain-washed in marine atmospheric environments where chlorides are deposited can experience a higher corrosivity category due to the presence of hygroscopic salts.

In environments with expected “CX category”, it is recommended that the atmospheric corrosivity classification from one-year corrosion losses be determined. One-year exposure tests should start in the spring or autumn. In climates with marked seasonal differences, a starting time in the most aggressive period is recommended.

The concentration of sulfur dioxide (SO_2) should be determined during at least one year and is expressed as the annual average. However, in Australia, SO_2 is so low in most environments that it is generally considered that it can be ignored, other than for specific industrial applications or extreme traffic examples.

Coastal areas are normally defined as between 50 metres to 1 Km inland from sheltered seas and between 1 Km and 10-50 Km from surf beaches depending upon prevailing winds and topography. More details and examples are available in AS 4312.

Fill Material

Fill material is a complex issue. Our default position is to attempt to pile through the fill, as fill can change the torque capacity relationship significantly. i.e. fill can result in very high torque readings which can be misinterpreted as sufficient capacity, however there may still be a risk that the piles may settle differentially over time.

Questions are:

- What is the depth of fill? What is the likelihood of settlement?
- What is the fill material? How will it change the torque / capacity relationship?
- What is the type of construction (ability to articulate)?
- What is the compaction of the fill? Can it be verified with penetrometer testing?
- Is there variability in material and compactive effort?
- Will there be any differential settlement over the structure?
- Can the slab be stiffened? i.e. can a stiffer slab like BIAX + piles be used?

3.0 How to Design

with the Katana Helical Plate Screw Pile

IN THIS SECTION:

Calculation of Building Loads
 SWL (Safe Working Load) vs ULS (Ultimate Limit State)
 Steel Capacity
 Soil Capacity
 Design Methods
 Determining the Appropriate Depth
 AS2870 and the Hs Rule
 Pre-Drilling
 Designing for Raised Floors
 Designing for Retaining Walls

Calculation of Building Loads

Calculation of Live and Dead structure loads

Ultimate Load Transmitted to Edge Beam, kN/m

Based on the typical dead loads (G), live loads (Q), and ultimate limit state loads (U) transmitted to the edge beam, the following line loads can be calculated.

a. Roof loads

- Live load = $6\text{m} \times 0.25\text{kPa} = 1.5\text{kN/m}$ (Q).
- Concrete tile roof DL = $6\text{m} \times 0.9\text{kPa} = 5.4\text{kN/m}$ (G).
- Metal sheet roof DL = $6\text{m} \times 0.4\text{kPa} = 2.4\text{kN/m}$ (G).
- Ultimate tile roof load = $1.2G + 1.5Q = 1.2 \times 5.4 + 1.5 \times 1.5 = 8.73\text{kN/m}$ (U).
Or $1.35G = 1.35 \times 5.4 = 7.29\text{kN/m}$ (U).
- Ultimate metal roof load = $1.2G + 1.5Q = 1.2 \times 2.4 + 1.5 \times 1.5 = 5.13\text{kN/m}$ (U).
Or $1.35G = 1.35 \times 2.4 = 3.24\text{kN/m}$ (U).

b. Brick veneer loads

- Single storey = $3\text{m} \times 2.44\text{kPa} = 7.32\text{kN/m}$ (G).

- Double storey = $6\text{m} \times 2.44\text{kPa} = 14.64\text{kN/m}$ (G).
 - Ultimate single storey load = $1.2\text{G} = 1.2 \times 7.32 = 8.78\text{kN/m}$ (U).
Or $1.35\text{G} = 1.35 \times 7.32 = 9.88\text{kN/m}$ (U).
 - Ultimate double storey load = $1.2\text{G} = 1.2 \times 14.64 = 17.57\text{kN/m}$ (U).
Or $1.35\text{G} = 1.35 \times 14.64 = 19.76\text{kN/m}$ (U).
- c. Timber / light gauge steel suspended floor loads –
- Live load = $3\text{m} \times 1.5\text{kPa} = 4.5\text{kN/m}$ (Q).
 - Timber suspended floor DL = $3\text{m} \times 0.9\text{kPa} = 2.7\text{kN/m}$ (G).
 - Ultimate single storey load = $1.2\text{G} + 1.5\text{Q} = 1.2 \times 2.7 + 1.5 \times 4.5 = 9.99\text{kN/m}$ (U).
Or $1.35\text{G} = 1.35 \times 2.7 = 3.65\text{kN/m}$ (U).
- d. Ground floor void slab
- Live load = $1.5\text{m} \times 1.5\text{kPa} = 2.25\text{kN/m}$ (Q).
 - Dead loads are slab self-weight = 3kPa
+ partition allowance = 0.5kPa
+ floor tile allowance = 0.5kPa
 - Total dead load = $4.0\text{kPa} \times 1.5\text{m} = 6.0\text{kN/m}$ (G).
 - Ultimate ground floor load = $1.2\text{G} + 1.5\text{Q} = 1.2 \times 6.0 + 1.5 \times 2.25 = 10.58\text{kN/m}$ (U).
Or $1.35\text{G} = 1.35 \times 6.0 = 8.10\text{kN/m}$ (U).

Various Line Loads to Edge Beam (Ultimate limit state) (Examples)

Single, Storey, Tile Roof, Brick Veneer Wall

Element	1.2G + 1.5Q	1.35G
Roof tiles	8.73kN/m	7.29kN/m
Brick veneer (3m)	8.78kN/m	9.88kN/m
Ground floor slab	10.58kN/m	8.10kN/m
Line load (ULS)	28.1kN/m	25.27kN/m

Controlling line load (ULS) = $1.2\text{G} + 1.5\text{Q} = 28.1\text{kN/m}$.

Single Storey, Metal Sheet Roof, Brick Veneer Wall

Element	1.2G + 1.5Q	1.35G
Sheet roof	5.13kN/m	3.24kN/m
Brick veneer (3m)	8.78kN/m	9.88kN/m
Ground floor slab	10.58kN/m	8.10kN/m
Line load (ULS)	24.5kN/m	21.22kN/m

Controlling line load (ULS) = 1.2G + 1.5Q = 24.5kN/m.

Double, Storey, Tile Roof, Brick Veneer Wall

Element	1.2G + 1.5Q	1.35G
Roof tiles	8.73kN/m	7.29kN/m
Brick veneer (6m)	17.57kN/m	19.76kN/m
Timber suspended floor	9.99kN/m	3.65kN/m
Ground floor slab	10.58kN/m	8.10kN/m
Line load (ULS)	46.9kN/m	38.80kN/m

Controlling line load (ULS) = 1.2G + 1.5Q = 46.9kN/m.

Double Storey, Metal Sheet Roof, Brick Veneer Wall

Element	1.2G + 1.5Q	1.35G
Sheet roof	5.13kN/m	3.24kN/m
Brick veneer (6m)	17.57kN/m	19.76kN/m
Timber suspended floor	9.99kN/m	3.65kN/m
Ground floor slab	10.58kN/m	8.10kN/m
Line load (ULS)	43.3kN/m	34.75kN/m

Controlling line load (ULS) = 1.2G + 1.5Q = 43.3kN/m.

Once the line loads have been determined, then the piles loads can be calculated based on the possible spacing of the piles.

SWL of piles in kN - (FOS = 1.5) based on the above ULS building load table * assuming the pile carries all the load and no load is distributed to the surrounding soil:

Pile Spacing	ULS Load (kN/m)	SWL Load (kN/m)	1.5m SWL kN	2.0m SWL kN	2.5m SWL kN	3.0m SWL kN
Single Story Brick Veneer Tile Roof	28.1	18.7	28.1	37.4	46.8	56.1
Single Story Brick Veneer Metal roof	24.5	16.3	24.5	32.6	40.8	48.9
Double Story Brick Veneer Tile Roof	46.9	31.3	47.0	62.6	78.3	93.9
Double Story Brick Veneer Metal Roof	43.3	28.9	43.4	57.8	72.3	86.7

SLS (Serviceability Limit State) vs ULS (Ultimate Limit State)

Piling contractors understand their product best at the SLS (also SWL - Safe Working Load). Engineers are encouraged to specify SWL on their drawings to avoid the piling contractor having to assume the factor of safety of the Ultimate Limit State.

The Pile (assume factor of safety FOS of 1.5)

	76.1x4 250x8 (kN)	76.1x4 300x8 (kN)	88.9x5.5 350x10 (kN)	88.9x5.5 2No 350x10 (kN)
SLS	7-200kN	10-200kN	14-230kN	41-300kN
ULS (SLS x FOS 1.5)	10-300kN	15-300kN	21-345kN	61-450kN
Approximate SLS (8m pile - very loose soil)	40kN	50kN	75kN	100kN
Approx Tension Load (depends on depth)*	1m - 5kN	2m - 35kN	3m - 118kN	4m - 280kN

* Wet sandy soil may have very low tension capacity.

Depending on the loads and how soft the soil is you may raise the issue of buckling on piles longer than 8m given even soft soil is going to provide some support to the pile.

Steel Capacity

CHS (Circular Hollow Section) - SWL (assume factor of safety of 1.5)

All values are Min based on 400 MPa. Actual steel strength will be greater than 100 Mpa	76.1x4 250x8 (kN)	76.1x4 300x8 (kN)	88.9x5.5 350x10 (kN)	88.9x5.5 2No 350x10 (kN)
Safe Working Load vs Ultimate Limit State	SWL	ULS	SWL	ULS
Compression (short pile)	217kN	326kN	345kN	518kN
Compression (8m pile)*	12kN	18kN	23kN	34kN
Tension	217kN	326kN	345kN	518kN
Bending Moment	3.5kN	5.3kN	6.8kN	10.2kN
Shear	68kN	102kN	112kN	168kN
Torsion	4470kNm	6705kNm	8153kNm	12230kNm

* Further detail below

Depending on the loads and how soft the soil is you may raise the issue of buckling on piles longer than 8m given even soft soil is going to provide some support to the pile.

The chart below shows how the axial capacity is reduced with increased length of the pile.

The piling contractor to ensure the axial strength is confirmed by the engineer.

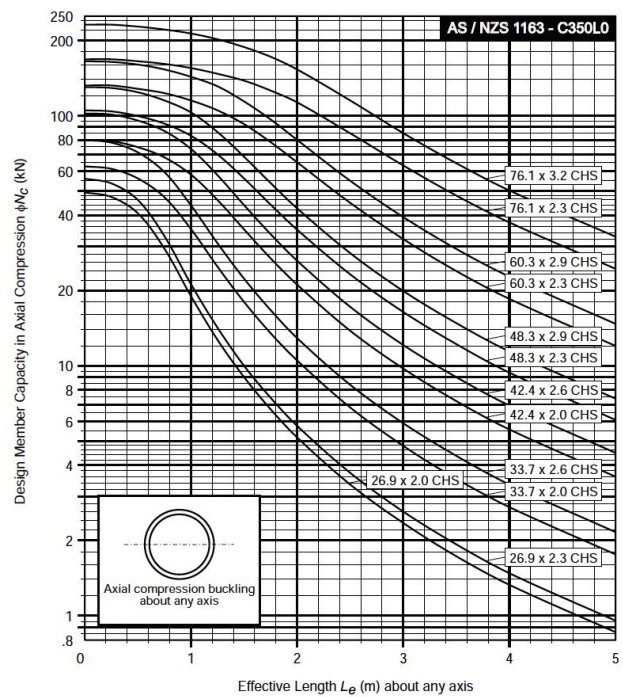
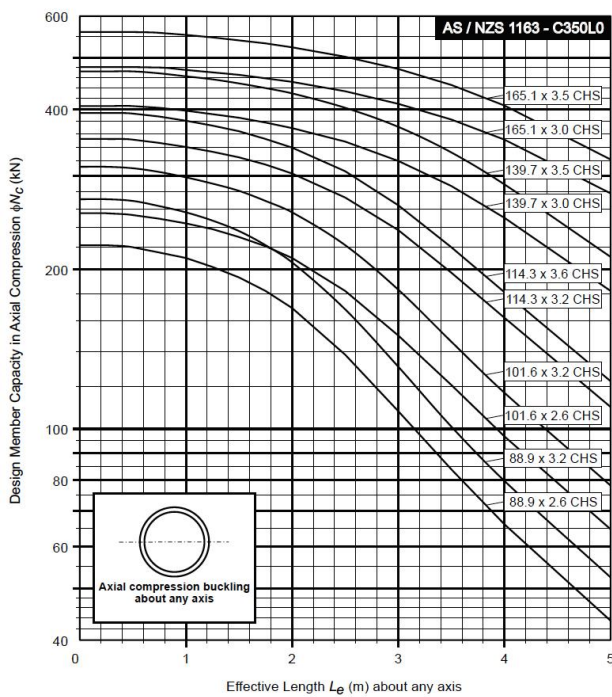

The Helical Plates

Basic plate bending analysis with both plates contributing 4kN of SWL mostly at the leading edge.

Ultimate load testing was then carried out on various soil types and the helixes inspected for any bending.

In loose / soft soils the strength of the plate / helix will always be more than the founding soil.

In the case of dense / hard soils, over time, the soil above the helix consolidates and the helix acts more in shear along the shaft rather than in bending.

Soil Capacity

A good general guide is the Practice Note 28 "Screw Piles: Guidelines for Design, Construction & Installation. Engineers New Zealand (IPENZ)

One theoretical approach is by Donald J. Clayton "Basic Helical Screw Pile Design".

Some rules of thumb are:

- Where piles are relatively long in loose soils (Penetrometer tests indicate loose material), reduced buckling capacity must be considered
- Screw pile helix are individually effective when spaced more than 3 helix diameters apart

N = Bearing capacity factors (Terzaghi 1943 and Meyerhof 1951)

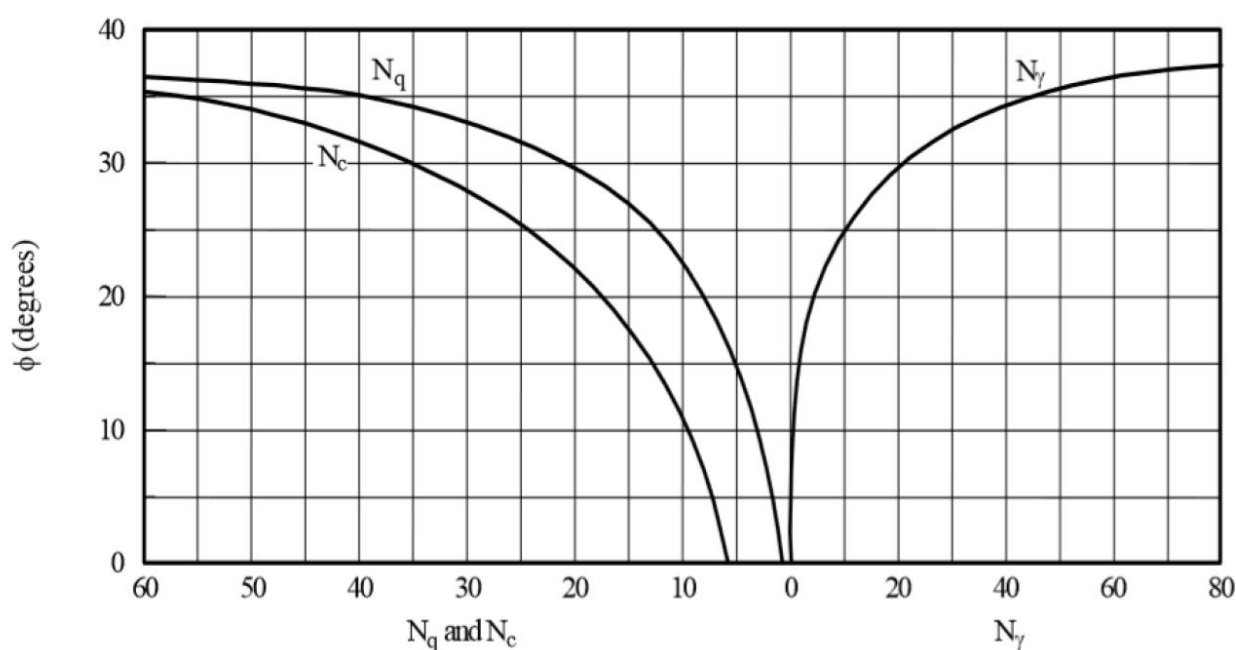

Capacity of a cohesionless sand = (area of helix) x (overburden) x N_q

For sand N_q is derived from the internal angle of friction ϕ

Capacity of a cohesive clay = (area of helix) x (shear strength) x N_c

For clay or $\phi=0$ $N_c = 9$ (Skempton 1951)

Several other theories exist such as Perko, Winkler, Walsh, Mitchell etc. Whatever theory the reader decides to adopt - it is always prudent to take the most conservative theoretical calculation.

Calculating the theoretical capacity of a screw pile is helpful to design the pile shaft, number and thickness of plates/helices, shaft diameter but it is only an approximation of what will occur in the field.

Pull up or compression testing on site or in the field, in areas where there may be uncertainty is always recommended by the screw piling company.

Design Methods:

1. Calculating Load Capacity, by Donald J. Clayton

There are numerous theories dealing with the calculation of screw piles load capacity. A working example of one theory is provided below. Calculating pile capacities by using a number of theories will give different answers and ultimately these calculations should be verified in the field by testing.

Katana Pile load table for various soil types - remember CAPACITY = Sum of areas of the helical plates (q Nq OR c Nc) + skin friction ignored:

Reference: Basic Helical Screw Pile Design, Donald J. Clayton, P.E.

<https://geotecheng.com/publications/guidelines>

Capacity of a **cohesionless sand** = (area of helix) x (overburden) x Nq

For sand phi is related to Nq

For a plate 250 mm in dia, depth of pile 3 m and sand with a density of 16 kN/m³ and phi = 32 deg, Nq = 81

Capacity = $0.0446 \times (16 \text{ kN/m}^3 \times 3\text{m}) \times 81 = 173 \text{ kN} / 1.5 = \mathbf{115 \text{ kN}}$

GUIDE CAPACITY TABLE - PILE IN SAND: Single Helix, Depth of Helix 3m (for shallow depths capacity will be lower), FOS 1.5 - Assumes pipe torsion will not be a limiting factor!

Soil Type	Density (kN/m ³) - phi	76.1x4 250x8 (kN)	76.1x4 300x8 (kN)	88.9x5.5 350x10 (kN)	88.9x5.5 2No 350x10 (kN)
SAND (Capacity varies with depth): Exposure Classification may limit maximum capacity of the pile					
Loose	15 - 28	53	79	107	179
Medium	16 - 32	115	171	230*	300*
Dense	17 - 36	200*	200*	230*	300*
Gravel with some sand	17 - 40	200*	200*	230*	300*
Silts	16 - 30	81	120	230*	300*

** Limited by helix weld assuming a helix shear weld failure*

Capacity of a **cohesive clay** = (area of helix) x (shear strength) x Nc

For clay or $\phi=0$ Nc = 9 (Skempton 1951)

For a plate 250mm in dia and a clay with shear strength of 100 kPa

Capacity = $0.0446 \times 100\text{kPa} \times 9 = 40.5\text{kN} / 1.5 = \mathbf{27\text{kN}}$

GUIDE CAPACITY TABLE - PILE IN CLAY: Single Helix, Depth of Helix 3m, FOS 1.5 - Assumes pipe torsion will not be a limiting factor!

Soil Type	Undrained Shear Strength (kPa)	76.1x4 250x8 (kN)	76.1x4 300x8 (kN)	88.9x5.5 350x10 (kN)	88.9x5.5 2No 350x10 (kN)
CLAY: Exposure Classification may limit maximum capacity of the pile					
Soft	25	7	10	14	41
Firm	50	13	20	27	81
Stiff	100	27	40	54	162
Very Stiff	200	53	79	108	324
Hard	>200				

GUIDE CAPACITY RANGE SUMMARY TABLE: Single Helix, Depth of Helix 3m, FOS 1.5 - Assumes pipe torsion will not be a limiting factor!

Soil Type	76.1x4 250x8 (kN)	76.1x4 300x8 (kN)	88.9x5.5 350x10 (kN)	88.9x5.5 2No 350x10 (kN)
Soft - Loose	7 - 53	10 - 79	14 - 107	41 - 179
Firm - Medium	13 - 115	20 - 171	27 - 230	81 - 300
Stiff - Dense	27 - 200	40 - 200	54 - 230	162 - 300
Very Stiff Clay	53	79	108	324
Silts	81	120	230	300

2. Estimating Safe Working Load from Installation Torque

An approximation of the capacity of a pile can be made from empirical evidence below. One needs to however understand that there are a number of variables and the answer can only ever be considered an approximation.

$$Q_u = KT$$

Q_u = ultimate capacity

K = Ratio (m⁻¹ / ft⁻¹)

T = Torque

From the regression analysis (Perko graph below) K is correlated to pile diameter and is different - metric vs imperial.

Assume we get 6kNm of torque on our 76.1mm pipe

$$K=27$$

$$Q_u = \text{ultimate load} = 27 \times 6\text{kNm} = 162\text{kN}$$

Our true blue pipe could be torqued to between 7.3kNm and 9.2kNm - above 160kN.

For our 88.9mm pipe assume a torque of 13kNm: $Q_u = 23 \times 13\text{kNm} = 300\text{kN}$

The governing factor is usually always the bearing capacity of the soil.

In the chart, there is clearly a variance in K and that is because torque and ultimate capacity can be affected by:

Pile: number and Helix diameter, helix thickness, helix pitch, shaft shape, connection detail

Soil: type, strength, stiffness, water table Installation: rotation rate, advance rate, down force

Testing: Load rate and increments, waiting time, interpretation

Care should be taken with K - but by all means use it to approximate the capacity of what your piling contractor has installed in the field.

The table below approximates the torque (Nm) and resulting pile capacity. This is only an approximation and should be verified by on site testing.

Ultimate Capacity	76 pipe DIA (Nm) $K_t=27m^{-1}$	88 pipe DIA (Nm) $K_t=23m^{-1}$	101 pipe DIA (Nm) $K_t=20.5m^{-1}$ (Approx)	114 pipe DIA (Nm) $K_t=18m^{-1}$
60kN	2300	2600	3000	3400
80kN	3000	3500	3900	4500
100kN	3700	4300	4900	5600
120kN	4500	5200	5900	6700
140kN	5200	6100	6800	7800
150kN	5600	6500	7300	8400
160kN	6000	7000	7800	8900
180kN	6700	7800	8800	10000
200kN	7400	8700	9800	11100

Torsional capacity of Katana min 400MPa CHS pipe listed below:

76.1mm x 4mm: 7000 Nm - 8000 Nm

88.9mm x 5.5mm: 12,500 Nm - 13,500 Nm

References:

“Helical Piles - A Practical Guide to the Design and Installation” Howard A. Perko 2009

Figure 6.6 page 179

Practice Note 28: Screw Piles – Guidelines for Design, Construction and Installation (2015)

Figure 6.5 page 16

<https://www.engineeringnz.org/engineer-tools/engineering-documents/practice-notes-and-guidelines/>

3. Approximate Helical Blade Sizing Method

There are numerous examples of empirical methods which relate **helical blade area**, to **Soil strength** to **Ultimate capacity**

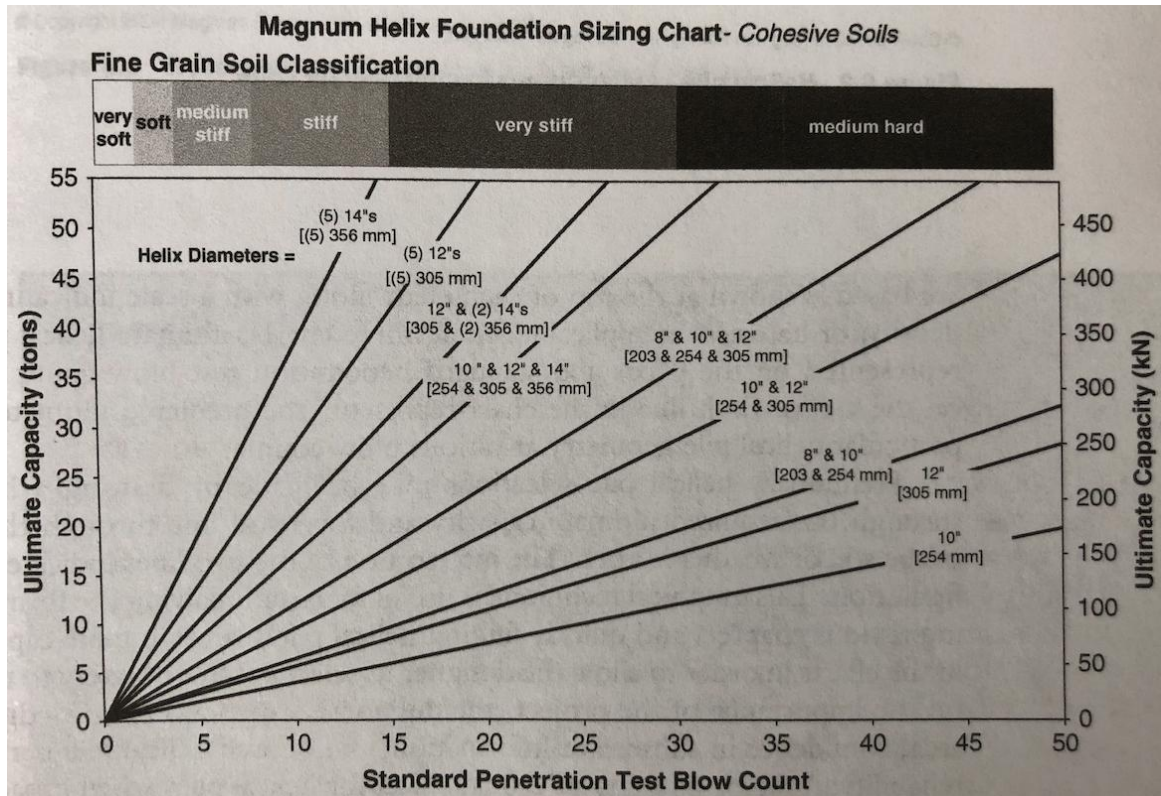

Reference:

"Helical Piles - A Practical Guide to the Design and Installation" Howard A. Perko 2009

Figure 6.6 page 179

Determining the Depth of the Pile

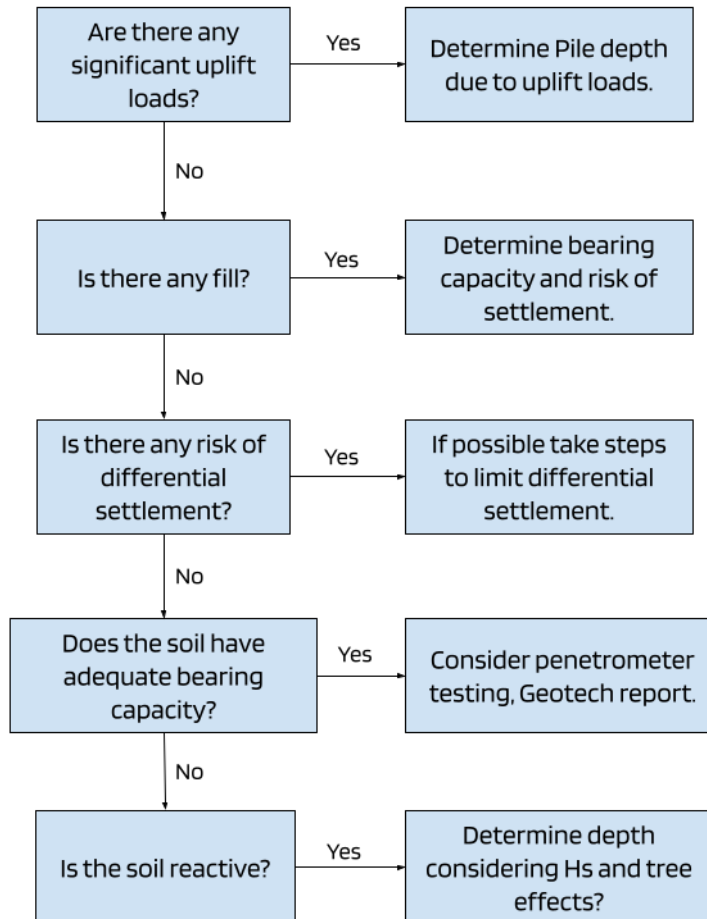

AS2870 and the H_s Rule

Katana's position is to consider the risk of movement where piles are not driven to $1.25H_s$ as per G6.3 of AS2870 - this clause applies $1.25H_s$ to all "reactive" soils irrespective of their reactivity or consideration of the likely movement below the pile.

G6.3 Minimum depth

The installed depth of screw piles in reactive foundations should not be less than $1.25H_s$, where H_s is given in Table 2.4. Where screw piles are used to support footing systems adjacent to deep service trenches, the depth of pile should be not less than the depth of the trench.

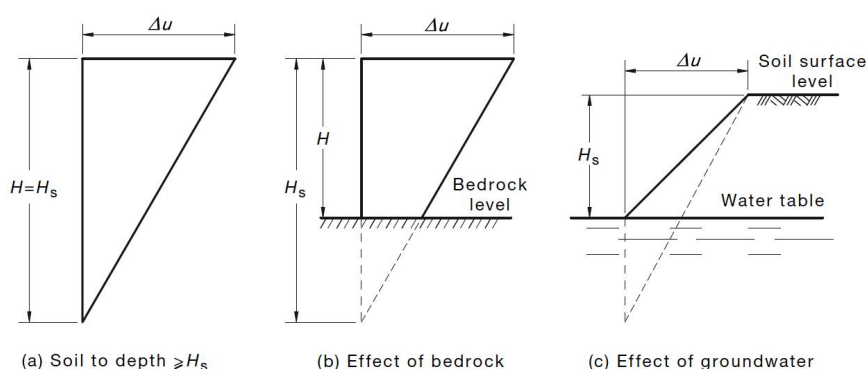

Δu and H_s are to be taken from Table 2.4 (except that H_s is taken as the depth to water table if it is less than the value in Table 2.4)

TABLE 2.4
SOIL SUCTION CHANGE PROFILES FOR CERTAIN LOCATIONS

Location	Change in suction at the soil surface (Δu) pF	Depth of design soil suction change (H_s) m
Adelaide	1.2	4.0
Albury/Wodonga	1.2	3.0
Brisbane/Ipswich	1.2	1.5–2.3 (see Note)
Gosford	1.2	1.5–1.8 (see Note)
Hobart	1.2	2.3–3.0 (see Note)
Hunter Valley	1.2	1.8–3.0 (see Note)
Launceston	1.2	2.3–3.0 (see Note)
Melbourne	1.2	1.8–2.3 (see Note)
Newcastle	1.2	1.5–1.8 (see Note)
Perth	1.2	1.8
Sydney	1.2	1.5–1.8 (see Note)
Toowoomba	1.2	1.8–2.3 (see Note)

NOTE: The variation in H_s depends largely on climatic variation.

Engineers and Katana Foundations will consider the likely movement of the pile referring to the reactivity of the soil below the pile and other factors such as tree effects..

Site Classification and expected movement (mm)	0.5Hs	0.75Hs	1.0 Hs	1.25Hs	1.5Hs (Tree Effect)
S (0-20)	0-10mm	0-5mm	0mm	0mm	?
M (20-40)	10-20mm	5-10mm	0mm	0mm	?
H1 (40-60)	20-30mm	10-15mm	0mm	0mm	?
H2 (60-75)	30-37.5mm	15-18.75mm	0mm	0mm	?
E (75)	>37.5mm	>18.75mm	0mm	0mm	?

Katana Foundations should rely on the design engineer to specify the depth of the pile or the certifier that certifies the pile installation.

Pre-Drilling

Clause G7 of AS2870 allows drilling to 90% of the min pile diameter.

We have found with tension testing that within a few weeks of the pile being installed, the ground around the pile has consolidated significantly and the pile performs to its capacity.

Where there is a concern that moisture may accelerate corrosion due to pre-drilling, we assume that good building practice will direct water away from the slab and it is good practice for the client to carry out testing as per AS2159 to confirm the exposure classification according to AS2159.

During the normal process of piling the ground for the helix diameter is disturbed in any event - predrilling only disturbs the ground marginally more than with no pre-drilling.

Designing for Raised Floors

Responsibility for design?

Katana Foundations are not design engineers and for any raised floor application, Katana's expectation is that the engineer designing the structure will undertake the design for the piles and related bracing above ground level.

Katana can provide the following:

1. Approximate screw pile lateral capacity by soil type at ground level
2. Drawings for bracing, bearer plates etc which the engineer may include in their design
3. A referral to consulting engineers that are familiar with the Katana Piling system for the builder to obtain a quotation for a design of the piles above the ground supporting the structure

How high can I have my building out of the ground?

Typically around 1.5 to 2m. The issue is really around trying to have one pilot pile (rather than extending the pile as this introduces movement into the system). A 5.5t excavator may only be able to install a 3.5m long pile.

The next consideration is the buckling capacity of the pile and the engineer may choose to use a 88.9mmx5.5mm pile rather than a 76.1mmx4mm pile.

It may be possible to have longer piles out of the ground but the engineer may want to consider a rigid / welded connection at ground level and a comprehensive bracing system.

Lateral Loading

Piles more than 500mm above the ground or in soft soil should be braced.

Improving the lateral capacity of the pile is possible with:

- Bracing piles
- Piles drilled on an angle and connected to the structure
- Horizontal cross bracing
- Concrete footings at ground level

It is always preferred to have piles that are only one piece with no extensions.

A full risk assessment and Safe Working Method must be developed by the client when sliding buildings on screw piles.

When buildings are "slid" into place, there is a concern about the lateral capacity of the pile and any eccentricity introduced on the pile.

In Australia rails are used on top of the piles to slide buildings into place.

In other circumstances a temporary steel beam can be used to slide buildings - which is removed when the building is in place by jacking the building to release the beam - however the piles need to be laterally supported during the sliding process.

Horizontal bracing or a permanent beam can also be used.

Rubber mats should be used between steel members to avoid the possibility of any sliding and higher corrosion rate between different steel materials.

Axial loading

All loads must be located on the centre line of the piles. **A MAXIMUM load of 80kN SWL is allowed for the Katana raised floor system.**

In the Technical Docs and Product Guide folder, there are some calculations for bearer plate capacity that can be used as a guide - subject to the engineer signing them off.

MUST BE CONFIRMED BY ENGINEER - Allowable bearer and slab plate loads

Where loads are eccentric to the centre of the pile, the appropriate bearer plate and supports must be designed for the additional bending moments introduced by the eccentric loads.

Connection details

Below are the standard bearer plate and connector plate options which can be provided to suit the 20 mm plate at the top of the Katana Pile.



The bearer plate connector (backing plate) may clash with the chassis in the corner and joists in certain locations.

Details of the ant cap are: [Termite Caps 100mm - Abey Trade](#)

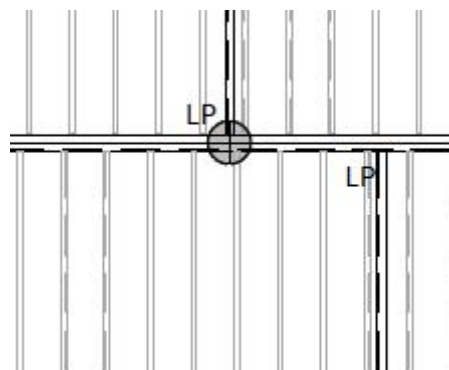

FIX: Engineer to reposition piles away from the edges and joists to avoid this clash or avoid the use of the backing plate as detailed below.

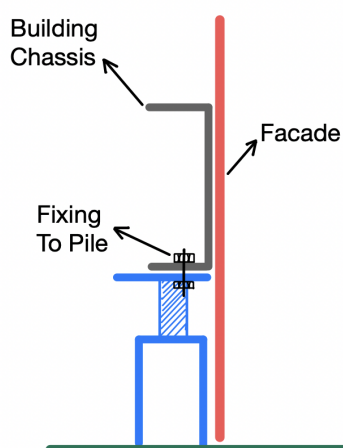

Bracing

Katana can provide a bracing system for raised floors. Ideally the raised floor is installed and the measurements taken in order to fabricate the bracing.

Alternatively the length of each member can be provided to Katana and Katana will label each member with an individual tag.

Bracing should be undertaken along continuous lines along the building (to minimise deflection at the top of the piles) and tightened only once the piles are under load.

A guide to lateral loading and deflection graphs for the Katana piles can be found in our **Katana Pile Product Statement**. <https://katanafoundations.com.au/foundation-systems/technical-resources/>

Structural engineers are free to use our bracing product but can also specify welding or bolting angle/RHS bracing etc to the piles - the engineer just needs to check any loss of section capacity with any bolting through to our piles.

The other option is a horizontal bracing system (acting as beams on ground) which will introduce bending moments into the piles.

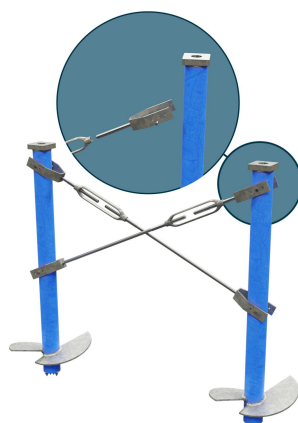

The design engineer specifies the tek screws to be used according to the bracing loads.

Tolerance

As the tolerance of the pile may vary up to $\pm 25\text{mm}$, the 200mm plate will accommodate this, but will need to be cut on site to match the outside edge of the chassis. The plate will need to be coated with an appropriate coating after it has been cut.

Raised floor summary

- The builder's engineer is responsible for the design of the connection details and bracing for the raised floor system. **A MAXIMUM of 80kN SWL allowed for the Katana raised floor system.**
- Lock nut is required to be installed on each pile on all raised floor systems.
- Katana Foundations can provide lateral capacity graphs and standard accessories, which must be designed by the builder's engineer.
- Katana Foundations **default coating system for raised floors is galvanising.**
- The builder takes full responsibility for any alternate coating systems specified.
- The builder is to provide set-out for the piling contractor and check the position of the piles during and subsequent to the installation being completed.
- **Piles will be loose when first installed** and it will take 1-2 weeks for material around the piles to settle and provide support to the pile. Where piles are pre drilled and / or extensions are used the builder may be required to install concrete pads around the screw piles, as designed by the builder's engineer.
- The builder is to fix and connect all bearers and bracing to the piles according to the builder's engineers details.

- Where piles are required to be cut on a raised floor system, please refer to Katana to determine any risk with uplift loads

Designing for Retaining Walls

Piles can be driven into the retained material and tied to the wall of the retaining wall or they can be staggered as per the example below in order to create a footing with the required moment capacity (working with axial tension and compression loads) to support the retaining wall.

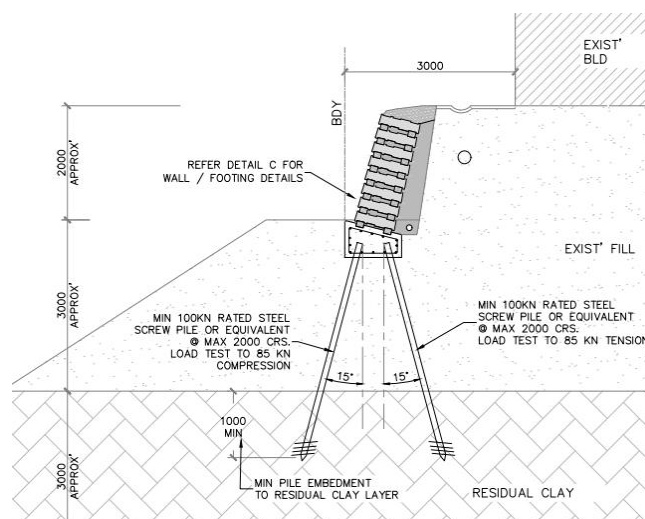
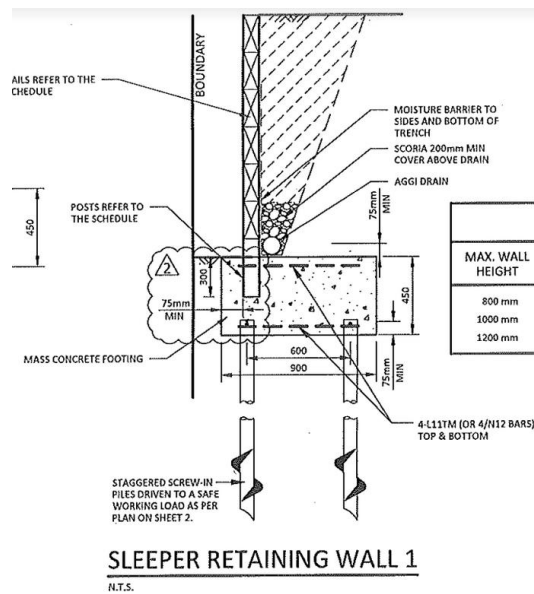

4.0 Katana Helical Plate Screw Pile Installation and Certification

IN THIS SECTION:

- Introduction
- Materials
- Site Preparation
- Installation Method
- Installation Procedure
- Pile refusal Procedure
- On Site Installation issues
- Conclusion

Introduction

The Katana piles shall be installed using specialised equipment correctly calibrated to allow torque reading to be monitored and recorded for each pile during installation.

The Katana piles shall be installed by an experienced accredited "Katana Piling" contractor.

Katana Pile installation tolerances

The maximum variation shall be no more than ± 25 mm from the plan position as shown on the drawings.

The Katana pile shaft shall be installed vertically with a variation of not more than 4% from the vertical.

The maximum variation of the cut-off level shall be ± 25 mm from that shown on the drawings.

The most common method adopted today in determining the installation depth of screw piles is purely based on the torque of the pile at the time of being installed. It has been identified that large inconsistencies can occur between the results of the site investigation and the final screw pile depth achieved when only using this method. This can clearly have large implications on the final cost of the pile installation, thus impacting on the final overall cost of the foundation system as a whole.

The Katana Pile has been developed as a concrete pier replacement to be installed to a nominated target depth as identified within the soil test and foundation design report. Rather than rely purely on torque as a means of measure, the installation depth of a Katana Pile may be determined/ confirmed by an onsite Uplift Load Test eliminates the possibility of installing piles, beyond what depth is required, thereby avoiding unnecessary cost.

This manual presents the minimum procedures for the nationwide conduct of the installation of the Katana Pile in accordance with the specifications and requirements of AS2159-2009 and meeting the minimum design parameters set out by the designing engineer within the soil test and foundation design report.

Scope

The scope of this document is focussed on the installation of the Katana pile for the purpose of residential and light industrial/commercial construction as outlined within AS2870-2011 'Residential Slabs and Footings'.

Construction uses outside the scope of this manual include but are not limited to the following:

- Commercial/ civil buildings or structures and associated applications
- Free standing retaining walls
- Light poles, signs etc.
- Roads, bridges and civil works
- Embankment stability

Questions to ask your piling contractor

1. Product development documentation - compression testing
2. Steel mill test results - is there traceability
3. Product drawings / corrosion reports
4. Observation of the product (welds, steel)
5. On site testing - pull out test
6. Auger calibration and torque/pressure
7. Independent third party accreditation - CodeMark / 9001

Builders responsibility

All service locations must be identified on site by the builder. It is the builders responsibility to clearly identify and notify Katana Foundations of all underground services, prior to screw piling works being conducted.

Should the locations of any underground services/works be within the engineered screw pile locations, Katana Foundations accepts no responsibility for any damage, time delays or costs incurred for rectification of such services/works.

Materials

Equipment register

The following outlines the minimum information and equipment that all Certified Katana Installers must have on site at the time of installation:

1. Latest Version of Architectural Drawings including siting plan and floor plans.
2. A full copy of the soil/ geotechnical test and foundation design report.
3. Installation Record Checklist.
4. Installation and Testing Manual
5. Uplift Testing and Installation Record Data Sheets (refer appendix).
6. Digital Camera or Phone for high resolution images.
7. Pile Uplift Load Testing Unit with Hand Pump and calibrated Bar Pressure Gauge. Approved testing devices only to be used. Devices are available from Katana Foundations.
8. Minimum 5 tonne Excavator or equivalent.
9. Appropriate earth drill/ drive motor attachment to suit excavator flow
10. Laser and receiver instrumentation to assess pad and pile levels
11. Perpendicular instrumentation for vertical alignment
12. Bar/ PSI pressure gauge for excavator
13. Pipe Cutting Device/ Reciprocator Saw or similar
14. Katana Pile Installation Adapter Tool
15. Appropriate number of Katana Piles to meet requirements of installation layout
16. Spare Katana Pile Extensions to gain adequate depth
17. Appropriate number of proprietary accessories as per engineering detail plan

18. Other consumables to assist with site survey, marking out, identification or cleaning.

Site Preparation

Site identification

Clearly it is imperative that the correct site be identified prior to any works being undertaken on any given site. It is the responsibility of the Certified Katana Installer to ensure the correct site has been identified.

The following should be checked prior to commencement on site:

- Assessment and completion of site specific SWMS
- Sufficient access for plant to gain entry
- Any spoil, debris, obstacles, steep slopes or other trades preventing the scope of work to start
- All surveying pegs and marks are visually identifiable



On-site preparation

Prior to the installation of any Katana Pile, the following site preparations must be undertaken to ensure the pile installed meets the requirements of the foundation method adopted within the design.

The Certified Katana Installer must be satisfied the ground pad is level (+ or - 100 mm) with confirmation from the builder/client.

Check and confirm that the peg layout on site matches the Architectural and Engineering Drawings supplied. Where these differ, do not proceed with installation until such time the builder and engineer are contacted for appropriate advice.

Upon confirmation that the peg layout is consistent with architectural and engineering drawings, mark out the screw pile locations in accordance with the engineering drawings taking into consideration possible step down levels within the future concrete slab.

Mark out the location of any excavated strip footings or isolated pad footings incorporated into the engineered design. Depth and width of footings are to be specified on engineering detail plans.

Review the soil test report and foundation design report to gain an understanding of the soil conditions and the minimum target depth required by the designing engineer. If in doubt, the installer must contact the designing engineer to clarify prior to installation.

Using PP, kPA, SWL, kN, DCP values are all relevant data to evaluate prior to confirming the type and length of the Katana pile with the nominated engineer.

Installation

What to look for in a geotechnical report

- Depth of undisturbed natural soil - ideally piles should be embedded in natural soil
- Boreholes should be deeper than the expected depth of the piles
- If there is a significant layer of fill - the piling contractor should request advice on the fill. Is it controlled? What settlement can be expected below the depth of the pile?
- In wet clays - the piling contractor will either provide additional helixes or drill deeper as they may not get the required minimum torque to verify capacity.
- In wet sands - the piling torque will generally be lower than expected due to the liquification of the sand during drilling, however sand is known to have good bearing capacity.
- Is information on Chlorides, resistivity, Ph, Acid Sulphates provided to determine the expected life of the piles.
- What is the depth of the water table?

- Is there any rock that may prove difficult to drill piles into.

Expand on what Katana can do to access previous drills in the area

With a database of many thousands of installations undertaken across Australia and sound relationships with many Geotechnical and Consulting Engineers - Katana is likely to have access to extensive information concerning a site where drilling is proposed to be undertaken.

Good piling practice guidelines (verified on site by an uplift or compression test)

Australian soils: Geotechnical report provides an indication of dense/stiff natural soil with a bearing capacity of 100kPa.

	76.1x4 250x8	76.1x4 300x8	88.9x5.5 350x10	88.9x5.5 2No 350x10
Safe Working Load (kN)	Torque (Nm)			
60kN	3000	3500	3000	
80kN	4000	4500	4000	
100kN	5000*	5500	5000	5000
150kN			6000	6000
200kN				9000

*must be in stiff / dense natural soil or rock

New Zealand soils: Geotechnical report provides an indication of dense/stiff natural soil with a bearing capacity of 100kPa.

	76.1x4 250x8	76.1x4 300x8	88.9x5.5 350x10	88.9x5.5 2No 350x10
Safe Working Load (kN)	Torque (Nm)			
60kN	4000	4500	4000	
80kN	5000*	5500	5000	
100kN			6000	6000
150kN				9000

*must be in stiff / dense natural soil or rock

In highly reactive soils we should comply with the "climatic zone of influence - H_s " - G6.3 of AS2870. $1.25 \times H_s$
- however the Design Engineer may specify a shallower depth.

G3 GEOTECHNICAL SITE INVESTIGATIONS

A geotechnical site investigation for the design of deep footings should be taken to a depth not less than 1.5 m beyond the founding depth of the footings, and not less than 1.5 times H_s for the site.

The geotechnical strength of the foundation should be determined by appropriate field and laboratory testing of the ground at depths relevant to the design. The information required from the site investigation, as defined in AS 2159, should also apply to this Standard for deep footings.

Piles to be founded in NATURAL ground - or well controlled fill (only as directed by the Design Engineer) so there are no surprises beyond the pile depth.

Where the depth cannot be reached as per the engineering notes - the piling contractor must take written instruction from the engineer and advise the builder/client of the necessary action.

Without written approval of a shallower drill depth from the engineer, the piling contractor may run the risk of the occupancy permit not being granted for the home or for potential damage to the home due to settlement.

Where there is a significant difference in torque readings across a site, consideration should be given as to the reasons for the differences and any potential differential SETTLEMENT which may result.

Where the ground is particularly loose - i.e. penetration tests indicate the soil is loose - consideration should be given to the potential reduction in SWL due to buckling.

The piling contractor should also understand at which point the piles may yield in torsion. Torsional yield depends on yield strength, diameter and thickness of the shaft of the pile.

**** Helical piles should NEVER be unscrewed if they are too low - a pocket of loose material will remain below the pile - always add an extension and cut to the required height.***

Installation Procedure

The installation process is to be undertaken by a two-man crew as a minimum, the Certified Katana Installer and an experienced offsider. All piling contractors installing the Katana Pile must be Certified by

Katana Foundations Australia Pty Ltd and certified as required by any state or local government specific legislation.

Where the site has been correctly identified and nominated site preparations have been completed and confirmed, installation of the Katana pile may be undertaken as follows:

Step 1: Attach drive head

Attach the appropriate Katana drive head to the excavator drill.

Step 2: Check pile length

Confirm that pile length supplied is consistent with the minimum requirements set out within the supplied engineering design.

Example 80kN, 100kN, 150kN @ 1M-4M length

Where in doubt contact the engineer prior to continuing installation.

Step 3: Choose location for first pile

Once pile size and length is confirmed, choose a suitable location for the initial pile, preferably at the rear of the site first working the way out to the street. The initial screw pile being undertaken is about determining the cut/ fill line and how much fill has been introduced after the original soil test was conducted. This method will confirm if the soil profile is consistent with the soil test investigation report or whether some changes in incremental size will be necessary to adjust.

Step 4: Commence first pile install

Commence the installation of the first Katana Pile to the minimum target depth as nominated, recording the pressure reading reached on the machine gauge using the Katana 'record sheet'.

Step 5: Uplift test

Once the target depth of the first pile has been achieved, the uplift load of the pile may be tested using the approved 'rapid uplift test device' in accordance with the procedures outlined. This process is required to be documented by video and photographic evidence.

Pile Uplift Load Testing Procedure

The uplift test has been developed to be used in material where – e.g. due to liquefaction of the sand, single graded sand, wet silts, the required torque is unable to be achieved but where the material has good bearing capacity.

Decision process:

1. Torque Achieved (1400psi - 4000Nm - 250mm helix)? No - proceed to 2.
2. Min depth 2m? Yes proceed to 3.
3. Profile the site to get an understanding of the torque's being achieved and understand if there will be an issue with differential settlement.
4. Perform a pull-up test (seek sign off from engineers at Katana and STA). Type of construction type (i.e. single story construction supported by material with good bearing capacity is less of a risk than double storey supported by material with poor bearing capacity)
5. NOTE - the deflection during the uplift test must be noted but it is only a function of the looseness of the material above the helix, not the bearing capacity of the material below the helix.
6. Compression test (anything less than 1200psi - 250mm helix)

The On Site Rapid Load Test can only be performed by an Certified Katana Installer. The procedure outlined below may be implemented upon the installation of the initial Katana pile as described above. The testing procedures are as follows:

Step 6: Achieve minimum target depth

Install the first Katana Pile to the minimum target depth as nominated within the foundation design report.

Step 7: Record pressure

Record the pressure achieved on the machine gauge at installation when at the required target depth.

Step 8: Perform rapid load test

Place the Rapid Load Testing Device over the Katana Pile, ensuring a level firm base under the test unit.

Note - Test is not suitable on piles installed at less than 2.0 meters depth.

Step 9: Attached connect threaded rod

Screw in the connecting threaded rod, placing the hollow cylinder jack over and securing with a washer and locking nut. As per illustrations below.

Step 10: Connect hand pump unit

Connect the hand pump unit (complete with calibrated bar pressure gauge) as shown in figure 2 below.



Step 11: Jack the ram

Jack the ram (contains 100mm stroke) pre-loading the test device allowing for potential settlement at base of the testing unit. This may vary depending on the extent of soils beneath the test unit. All persons should be located a minimum of 3 meters clear of the testing unit prior to jacking.

Step 12: Jack until required capacity achieved

Once pre loading is completed and there is no further settlement observed, continue jacking the ram until such time the required PSI capacity nominated by the engineer has been achieved. Typically the measured uplifting load is ~ 100 % of the calculated load-bearing capacity of the pile.

RCH-20100 for 80kN / 8 Tonne pile must read 4,000psi

RCH-30100 for 80kN / 8 Tonne pile must read 2,700psi

GHC20100H			GHC30100H		
psi	kN	T	psi	kN	T
0	0	0	500	15	2
500	10	1	1000	30	3
1000	20	2	1500	45	5
1500	30	3	2000	60	6
2000	40	4	2350	71	7
2500	50	5	2700	81	8
3000	60	6	2850	86	9
3500	70	7	3350	101	10
4000	80	8	3500	105	11
4500	90	9	4000	120	12
5000	100	10	4500	135	14
5500	110	11	5000	150	15
6000	120	12	5500	165	17
6500	130	13	6000	180	18
7000	140	14	6500	195	20
7500	150	15	7000	210	21
8000	160	16	7500	225	23
8500	170	17	8000	240	24
9000	180	18	8500	255	26
9500	190	19	9000	270	27
10000	200	20	9500	285	29
			10000	300	30
20100	10000psi = 20T		30100	10000psi = 30T	

Step 13: Maintain pressure for 5 mins

Maintain minimum constant pressure on the pile at load capacity requirement for a minimum of 5 minutes ensuring the pile does not displace.

Step 14: Record pressure

Record bar pressures achieved on the supplied record sheets (refer appendix) and document using photographs or video evidence.

Step 15: Pass conditions

Where the tested pile continues to hold the required load capacity with no displacement for the minimum time specified, it can be confirmed the screw has passed the load requirements nominated.

Step 16: If the pile fails

Where the tested pile fails to hold the required load capacity, that is to say the pile HAS displaced under load, the test has failed, confirming the pile has NOT achieved the required load capacity. In this situation, the pile depth is to be extended using Katana Pile Extensions, then repeat the test as described until such time the required load capacities have been achieved.

Step 17: Install remaining piles

With test pile complete and target depth confirmed, the remaining piles are to be installed to the nominated target depth as outlined within the soil test and foundation design report and as confirmed with the initial test pile. Note, the pressure to which the remaining piles are installed must match or better the bar pressure achieved at the time of the test pile. In the event that the pressure reading value is lower than that of the initial test pile, the Uplift Load Test must be repeated to ensure the bar pressure acquired meets the minimum load capacity required.

Step 18: If further fails occur

Where any pile fails to meet the required load capacity, pile extensions must be added until the required load capacity is achieved.

Step 19: Documentation

Record and document the installation of all piles including the pile number, final depth achieved for each pile, length of pile used to include any extensions and minimum bar pressure achieved at final installation depth.

Step 20: Final inspection

Upon completion of the pile installation and prior to leaving the site, the piling contractor must inspect/ review all piles installed to confirm that the correct number, location and final height of piles have been installed in accordance with the engineering drawings and architectural plans supplied.

Pile Refusal Procedures

Where difficulties are experienced in achieving the minimum required pile depth due to very stiff to hard soils, cobble or contaminated ground, the pre-drilling of a pilot hole for the Katana pile prior to installation may be required.

This is to involve drilling a 150mm diameter specialised auger in the location of the required screw pile, extending the hole to the target depth, or until such time the unfavourable ground has been penetrated. Once drilled, continue to install the screw pile as required.

In the instance where the screw pile installation refuses onto the natural rock profile, it can be assumed that the pile has reached the typical 80kN load capacity required, therefore the testing of individual piles is not considered necessary - refer this scenario to the engineer for their approval.

Where piles encounter the weathered rock profile, thus not allowing the pile to be installed to the required RL, the pile top may be cut by use of a power tool or similar to achieve required lasered height. (see figs below) - refer this scenario to the engineer for their approval.



On Site Installation Issues

Differential settlement

One of the most important factors with residential piling is differential settlement. Where a site is cut on one half and filled on the other half and the installation torques during installation reflect this, then potentially there could be a concern around how the home will settle and where the cracking will take place.

As on site soil conditions can vary considerably over relatively short distances, particularly within Australia, some issues can arise from time to time with regards to the installation of screw piles.

Issues pertaining to torque or depth requirements must be directed to the engineer, this includes any design issues pertaining to the requirements of the foundation design as a whole.

Where issues pertaining to the supply or delivery of the Katana Pile or Accessories, these queries are to be directed to the manufacturer.

The checklist below are the minimum requirements that must be recorded and supplied by the Certified Katana Installer to the engineer in order for final certification to be issued on the installation of the Katana Pile. This information is to be recorded on the approved Screw Pile Installation Checklist (refer appendix)

Document job details including the following:

- Site Address
- Certified Katana Installer
- Engineer Report Job No.
- Installation Date
- Principal Contractor

Document details of the pile type used including the following:

- Pile Type
- Design Load
- Pipe Diameter
- Founding Material
- Helix Size

Site photographic evidence is required for record keeping.

Results of the initial Uplift Load test which are to be recorded on the supplied record data sheet.

Video footage or photographs of the initial Uplift Load test are to be taken. Showing clear gauge read and surrounding location.

Record and document the installation of all piles including the pile number, final depth achieved for each pile, length, extensions, pressure, accessory and any cut increments also.

A corresponding layout is to be provided showing the location and the number allocated to the screw pile installed.

Photograph the site and accessories left on site upon completion of installation. A minimum of 4 photographs are required.



Approved Piling Contractor must submit all documentation supplied.

Certification

In order for final certification to be issued with regards to the installation of the Katana Pile, the information listed above must be supplied for certification.

Appendix A: Screw Capacity for Uplift Loads

Where uplift is specified and piles are cut, there is the option to use an M8 heavy duty Tri-Fixx screw which is rated to 9kN SWL which will increase the capacity of the pile to the capacity of the edge tie.

<p>Tri-Fixx M8 Heavy Duty Self Drilling Screw * Product Page Specification Sheet</p> 	<p>Buildex 14-20 Hex Head Full Thread Tek's Climaseal 4 31293-PDS Product Page Specification Sheet</p> 	<p>Bunnings Zenith Screws Not to be used</p> 
---	---	---

** The Tri-Fixx M8 heavy duty screw needs to be drilled at a slower speed of less than 100rpm in order for the screw to start cutting the steel - high speed drilling of this screw will only heat treat the steel making it impossible for the screw to penetrate the steel.*

Appendix B: Capacity of Edge Beam Connector

Some engineers may specify reinforcing through a hole towards the top of the pile. The reinforcing is usually 29 diameters (29D) long to get full embedment of the reinforcing into the concrete.

Katana Foundations uses a N16 (250mm long) edge tie, embedded into the concrete footing.

We have tested piles to failure (uplift) with the embedded edge tie and achieved a failure load of **55kN (Ultimate load)** in uplift per pile or 110kN for two piles or **27.5kN (SWL) - per pile. The capacity of 27.5kN satisfies most residential applications.**



Test Results

Test results of both uplift and lateral test undertaken on separate slabs, had given the test result of 110kN with a concrete strength of 25MPa. The test was undertaken on a concrete slab 19 days after initial pour. The results are as stated below.

Applied Load Type	Maximum Load Achieved
Vertical	11 Tonnes (110 kN)
Lateral	11 Tonnes (110 kN)

The Katana Piles were installed to an 80kN SWL at a depth of 2 metres with a spacing of 3 metres between each pile. The "Adjustable Edge Connectors", steel cage and slab mesh were installed as per this design manual. Taking into account the fact that this was a destructive test and only one undertaken for both "Lateral" and "Uplift" and the Katana

Pile configuration, we can surmise the following:

In the Uplift mode, we contend that the load pressures distributed over the three piles, that the middle pile withstood a minimum 50% of the load. Also taking into account we base this on one test, we will use a FOS (Factory of Safety) of 2.0. In Lateral mode, we contend that the distribution of load was equal across the three Katana Piles.

Calculation:

Uplift $(110\text{kN} / 2) / \text{FOS} = 27.5 \text{ kN per pile}$

Lateral $(110\text{kN} / 3) / \text{FOS} = 18.3 \text{ kN per pile}$

In conclusion, the connections have significant capacity to achieve the required loads, both in uplift and lateral.

Capacity of the Edge Beam Connector:

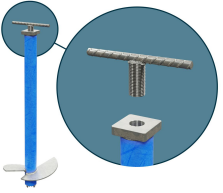
	<p>Capacity of threaded rod: Dia = 31 mm Area = 754.8 mm²</p> <p>Fy = 800 MPa (rod)</p> <p>F (Ultimate) = Fy x Area = 603.8 kN FOS = 2</p> <p>F (SWL) = 301.9kN</p>	<p>Capacity of the weld:</p> <p>Fillet weld size = 8mm Length = 20mm x 2 (sides) = 40mm Area = 320 mm²</p> <p>Fy = 480 MPa (weld)</p> <p>F (Ultimate) = Fy x Area = 92.2 kN FOS = 2</p> <p>F (SWL) = 46.1 kN</p>	<p>Shear Capacity of N16 bar:</p> <p>Diameter = 16mm Area = 201 mm²</p> <p>Fy = 500 MPa (bar)</p> <p>F (Ultimate) = 0.62 x Fy x Area = 99.7 kN FOS = 2</p> <p>F (SWL) = 49.9 kN</p>
---	---	--	--

Appendix C: Lateral Load Capacity Tables

Katana Pile - 80kN Lateral Performance in Clay



Pile Properties	
Pipe Diameter, d (mm)	76
Wall Thickness (mm)	4.0
Steel Grade (F's)	400
Pile Base Dia. (mm)	250

Typical Soil Properties (undrained)		
Soil Strength	Angle of Friction (deg)	Undrained Cu (kPa)
Stiff	0	100
Medium	0	60
Soft	0	30

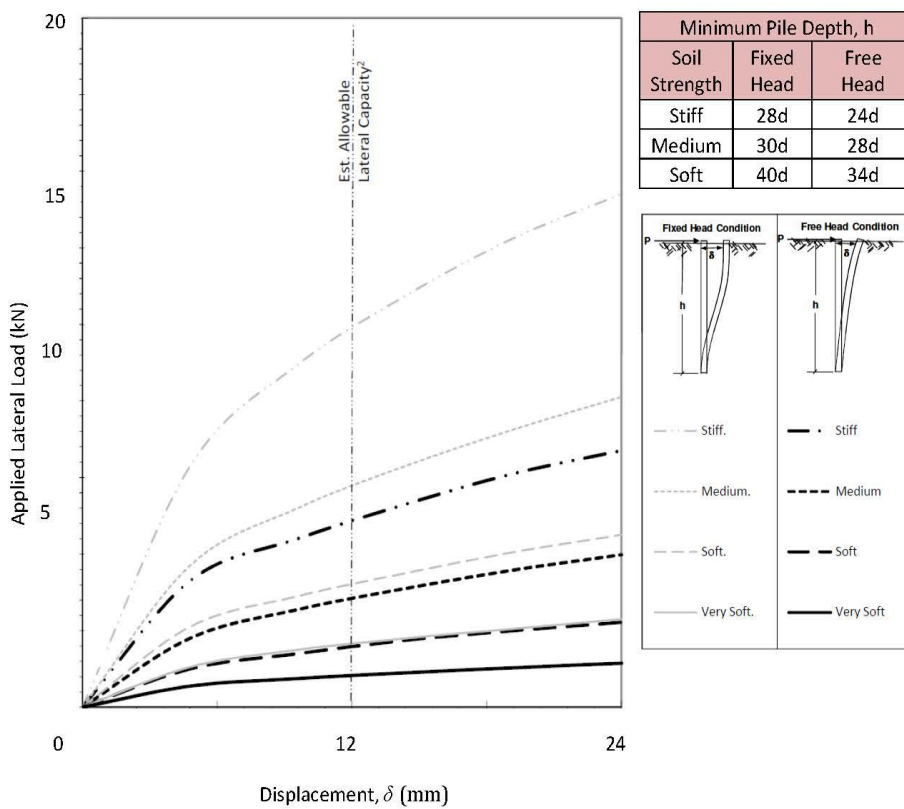

These charts are for Katana Piles only as lateral performance is highly dependent on the connections rigidity and shaft properties. It is Katana's opinion that these graphs represent a reasonable approximation of the average performance of the Katana Pile in the indexed soils. Using the average performance is reasonable for multiple redundant structures (e.g. buildings, bridges, marina piers, etc.)

AS2159 - 2009, states that the allowable lateral capacity of a pile is half load causing a 25mm of displacement. Many practitioners take this to be nearly the same as the lateral load predicated at 12mm displacement. The graph presented here can be used to evaluate capacity for either condition as well as to judge lateral performance under other displacement criteria and codes. The design allowable displacement is the responsibility of the design engineer.

Katana Pile - 80kN Lateral Performance in Sand



Pile Properties	
Pipe Diameter, d (mm)	76
Wall Thickness (mm)	4.0
Steel Grade (f's)	400
Pile Base Dia. (mm)	250

Typical Soil Properties		
Soil Density	Angle of Friction (deg)	Cohesion (kPa)
Dense	33	0
Medium	29	0
Loose	25	0

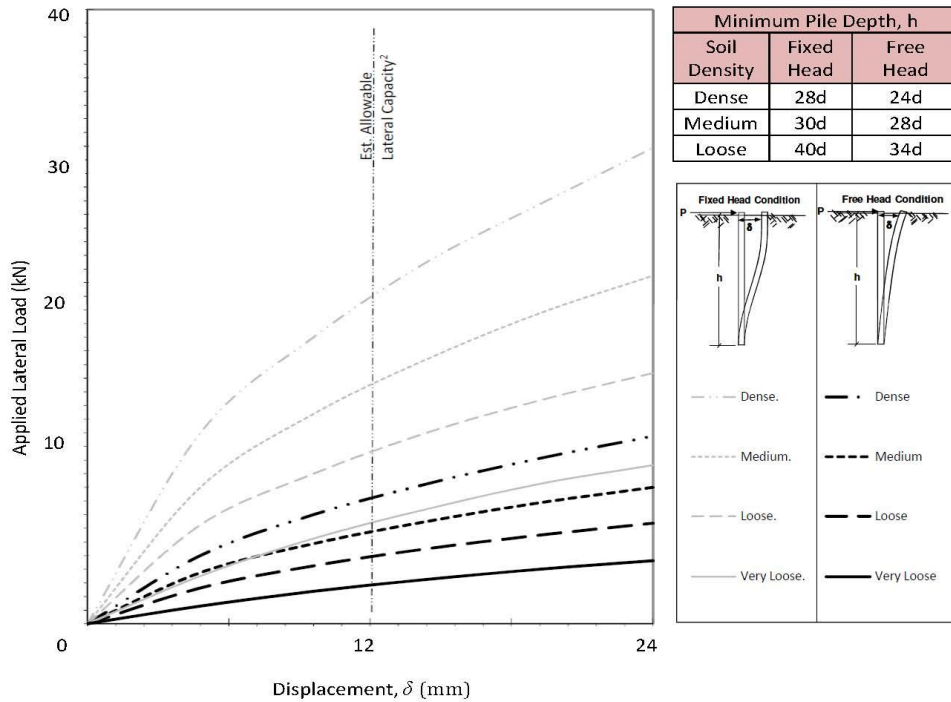

These charts are for Katana Piles only as lateral performance is highly dependent on the connections rigidity and shaft properties. It is Katana's opinion that these graphs represent a reasonable approximation of the average performance of the Katana Pile in the indexed soils. Using the average performance is reasonable for multiple redundant structures (e.g. buildings, bridges, marina piers, etc.)

A52159 - 2009, states that the allowable lateral capacity of a pile is half load causing a 25mm of displacement. Many practitioners take this to be nearly the same as the lateral load predicated at 12mm displacement. The graph presented here can be used to evaluate capacity for either condition as well as to judge lateral performance under other displacement criteria and codes. The design allowable displacement is the responsibility of the design engineer.

Katana Pile - 150kN

Lateral Performance in Clay



Pile Properties	
Pipe Diameter, d (mm)	89
Wall Thickness (mm)	4.0
Steel Grade (f's)	400
Pile Base Dia. (mm)	350

Typical Soil Properties (undrained)		
Soil Strength	Angle of Friction (deg)	Undrained Cu (kPa)
Stiff	0	100
Medium	0	60
Soft	0	30

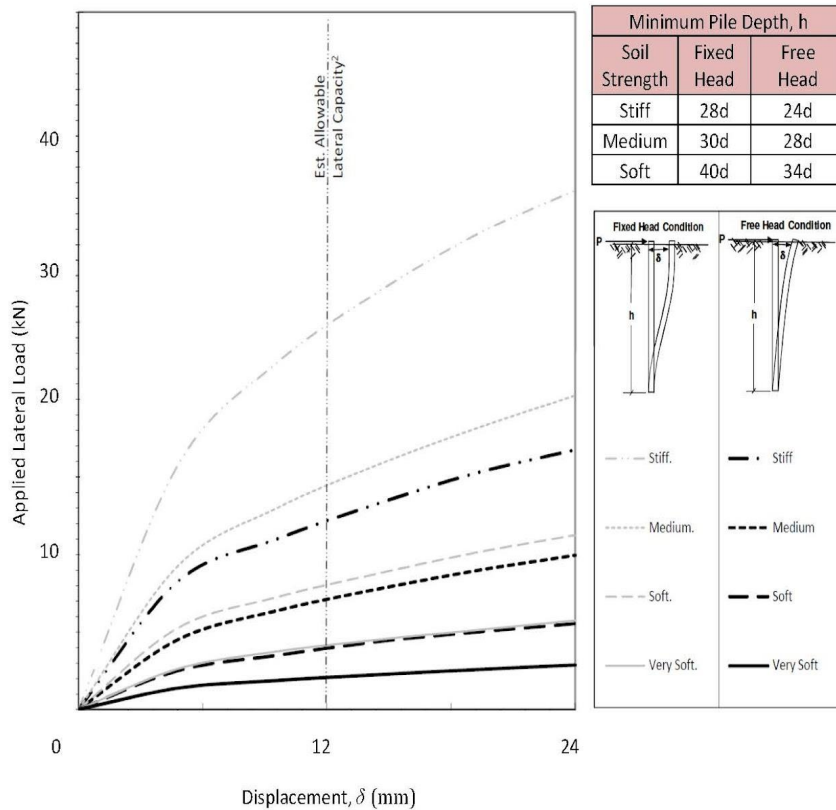

These charts are for Katana Piles only as lateral performance is highly dependent on the connections rigidity and shaft properties. It is Katana's opinion that these graphs represent a reasonable approximation of the average performance of the Katana Pile in the indexed soils. Using the average performance is reasonable for multiple redundant structures (e.g. buildings, bridges, marina piers, etc.)

AS2159 - 2009, states that the allowable lateral capacity of a pile is half load causing a 25mm of displacement. Many practitioners take this to be nearly the same as the lateral load predicated at 12mm displacement. The graph presented here can be used to evaluate capacity for either condition as well as to judge lateral performance under other displacement criteria and codes. The design allowable displacement is the responsibility of the design engineer.

Katana Pile - 150kN

Lateral Performance in Sand



Pile Properties	
Pipe Diameter, d (mm)	89
Wall Thickness (mm)	4.0
Steel Grade (f's)	400
Pile Base Dia. (mm)	350

Typical Soil Properties		
Soil Density	Angle of Friction (deg)	Cohesion (kPa)
Dense	33	0
Medium	29	0
Loose	25	0

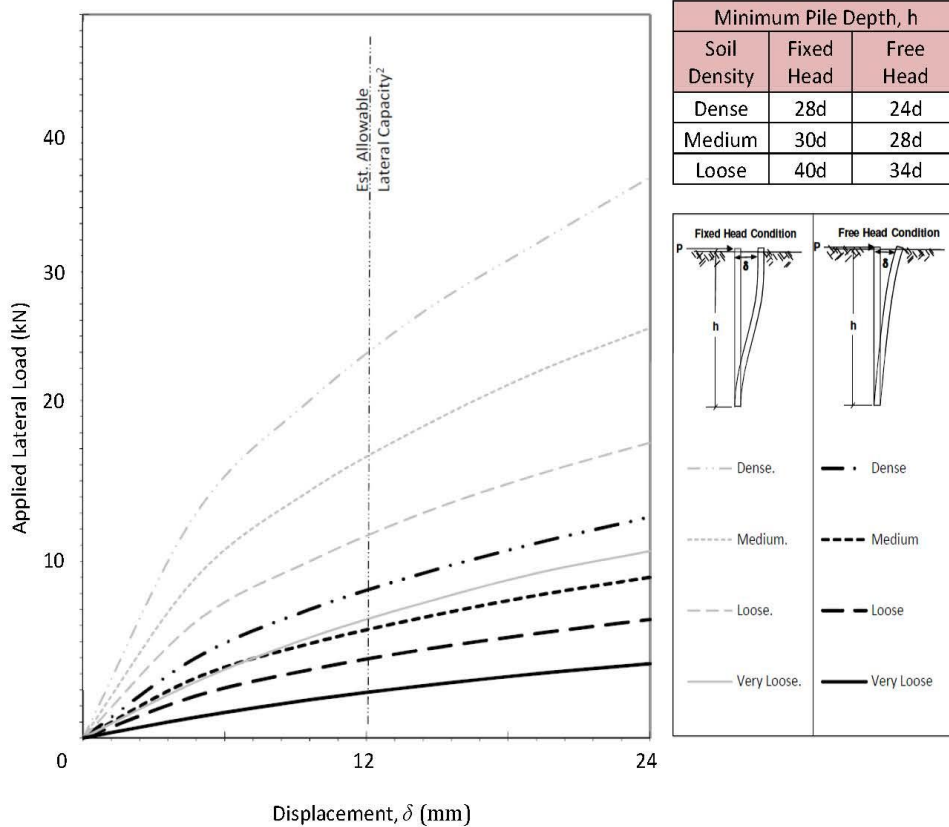

These charts are for Katana Piles only as lateral performance is highly dependent on the connections rigidity and shaft properties. It is Katana's opinion that these graphs represent a reasonable approximation of the average performance of the Katana Pile in the indexed soils. Using the average performance is reasonable for multiple redundant structures (e.g. buildings, bridges, marina piers, etc.)

AS2159 - 2009, states that the allowable lateral capacity of a pile is half load causing a 25mm of displacement. Many practitioners take this to be nearly the same as the lateral load predicated at 12mm displacement. The graph presented here can be used to evaluate capacity for either condition as well as to judge lateral performance under other displacement criteria and codes. The design allowable displacement is the responsibility of the design engineer.

Revision Control

Date	Revision
6 Mar 2023	SWL load capacity table for compression, tension, shear and bending
16 Aug 2022	Bearing and stress table for pile drive nut amended
2 Aug 2022	Slab plates removed (redundant due to Uni of Melbourne study)
29 Mar 2022	Plastic slab plate added and appendices added
24 Jan 2022	Raised floor notes modified and Perko table revised
18 Jan 2022	Additional compliance questions added and Denso SteelGard 400 added
29 Sep 2021	Load torque guidelines added in the Installation & Certification section
17 Sep 2021	Helix size error fixed in load table
18 Aug 2021	Engineering details added
28 Jul 2021	Bearing stress table updated
20 Jul 2021	Compliance questions added for certification
10 Jun 2021	Bearing stress table updated
3 Jun 2021	Error fixed in load / spacing table
18 May 2021	Concrete bearing stress added
14 May 2021	Commentary on fill material added
14 Apr 2021	Performance summary tables added for uncut and cut piles
9 Apr 2021	Perko torsion table extended, approx torsional capacity of Katana Pipe added below Perko table
22 Feb 2021	Clarification of Hs

Installer Certification Questions and Answers:

Q: What **Torque Nm** or **Hydraulic Pressure psi** is required under normal circumstances to achieve a minimum load of 80kN on a Katana Pile (250x8mm helix and 76.1x4mm shaft)?

A: _____

Q: What is the benefit of using something like a **Torque Hub** on your digger for installing piles?

A: _____

Q: At what depth (*in very loose soils) for a 76mm DIA pile would you start to get concerned about the reduction in **buckling capacity**?

A: _____

Q: What is best practice when faced with a site with **fill material**?

A: _____

Q: What test is the best way to **demonstrate the load capacity** of a screw pile?

A: _____

Q: What 4 things determine the **exposure classification** in AS2159?

A: _____

Q: In reactive soils - what is the "**Zone of Influence**" ?

A: _____

RAISED FLOORS:

Q: What **coating system** would you recommend for screw piles out of the ground supporting a raised floor?

A: _____

Q: What should you check **when you cut a Katana Pile** for a slab and a raised floor?

A: _____

Q: What is the **maximum load** on a Katana Foundations **raised floor per pile**?

A: _____

Q: Where should the floor bearer be located on a **Katana bearer plate**?

A: _____

Q: Who should do the **setout and check the pile positions**, once installed for a raised floor?

A: _____

Q: Who should do the design of the bracing and check that the Katana bearer plates, L brackets etc are suitable to carry the building loads for a raised floor?

A: _____

Q: What is **something you learned** that you did not know before the compliance session?

A: _____

A: _____

A: _____

Installer Certification (questions on the previous 2 pages are required to be answered)

Accreditation of Certified Katana Installers on behalf of

Katana Foundations Pty Ltd
ABN 67 163 915 786

CERTIFIED KATANA INSTALLER:

I have read and understood the contents of the Compliance Manual for the installation of "Katana" screw piles

Date: _____

Name: _____

Company: _____

Signature: _____

APPROVED KATANA FOUNDATIONS REPRESENTATIVE:

I have explained the contents of the Compliance Manual for the installation of "Katana" screw piles and hereby certify the Katana Installer to undertake installations on behalf of Katana Foundations Pty Ltd

Date _____

Name: _____

Position: _____

Signature: _____